



Device for Film Analysis



© 2026 *Mess- & Analysensysteme Golombek GmbH*

All rights reserved.

The company *Mess- & Analysensysteme Golombek GmbH* reserves the right to change or modify the device in order to improve and develop it technically. Such changes or modifications will not be documented in each single case. This operating manual and the information contained therein have been drawn up and compiled carefully. Any reproduction, in full or in part, requires the prior consent of the company *Mess- & Analysensysteme Golombek GmbH*



Device	Film analysis
---------------	---------------

Identification data

Inventory number	
Equipment number	
Location	

Customer information

Company name	Mess- & Analysensysteme Golombek GmbH
Street	Eichhaldenstr. 73
Place	D-71720 Oberstenfeld
Telephone	+49 (0)7062 5607
Fax	+49 (0)7062 3873
E-mail:	info@folienanalyse.de
Website	www.folienanalyse.de

Operator address

	For address see above
--	-----------------------

**Spare parts and
customer service**



Document information

Document number of operating manual	
Version	3.2
Draft date	02.03.2012
Latest revision	15.03.2026

Original manual

Purpose of document

This operating manual intends to make familiar the device operator with

- its mode of operation;
- its operation;
- the safety instructions; and
- its maintenance.

Operating personnel

The device must be operated by instructed and trained personnel only who is familiar with function, operation and safety instructions of the device. Such instructions must be documented in the acceptance certificate.



NOTE!

**Always keep this operating manual near the device!
This manual must be within reach at any time!**



Table of Contents

Table of contents		Page
1	Safety instructions	8
1.1	Obligations and liability	8
1.2	Safety icons	9
1.3	Hazard pictograms.....	10
1.4	Mandatory action signs	11
1.5	Intended use	12
1.6	Inappropriate use	12
1.7	Limitations of device	13
1.8	Organisational measures	13
1.9	Safety equipment.....	13
1.10	Informal safety measures.....	13
1.11	Safety measures in normal mode of operation	14
1.12	Hazards through electric energy	14
1.13	Specific hazards	14
1.14	Preventive and corrective maintenance, troubleshooting	14
1.15	Cleaning of device and disposal	15
1.16	Device noise	15
1.17	Accident prevention regulations, industrial safety regulations.....	15
2	Device description, technical data.....	16
2.1	Overall view of device for film analysis	16
2.2	Workplaces.....	16
2.3	Hazard zones	16
2.4	Device labelling	17
2.5	Technical data	18
3	Design and function of device.....	19
3.1	Mechanical design and legend	19
4	Transport and storage	20
4.1	Means of transport.....	20
4.2	Safety instructions for transport.....	20
4.3	Preparing for transport.....	20
4.4	Transport in original packing	21
4.5	Transport unpacked.....	21



Table of contents.....	Page
5 Installation and commissioning.....	22
5.1 Installing device.....	22
5.2 Connecting to power supply.....	22
5.3 Supplies.....	23
5.4 Commissioning.....	24
5.5 Preparations.....	24
5.6 Switch on device and check function.....	26
6 Operation of device.....	26
6.1 Computer-aided measurement.....	26
6.2 First measurement.....	27
6.3 Program description.....	35
6.3.1 Basics.....	35
6.3.2 Main screen.....	35
6.3.3 Main screen menu.....	37
6.3.4 Screen: Save.....	39
6.3.5 Screen: Load.....	41
6.3.6 Screen: Diagram.....	42
6.3.7 Screen: Box.....	43
6.3.8 Screen: Delete graph/pattern from disc.....	45
6.3.9 Screen: Create directory.....	46
6.3.10 Screen: Delete directory.....	47
6.3.11 Screen: Limit value management.....	48
6.3.12 Screen: Measurement.....	51
6.3.13 Screen: Adjustments.....	52
6.3.14 Screen: Results.....	54
6.3.15 Screen: Import graphs/patterns.....	55
6.4 Result analysis.....	56
6.4.1 Maximum curing speed.....	56
6.4.2 Curing time.....	57
6.4.3 Curing speed.....	58
6.4.4 Flow time.....	59
6.4.5 Flexibility.....	61
6.5 Switch off device in case of emergency (Emergency Stop).....	61
6.6 Restart after stop.....	61
6.7 Switch off device.....	61
6.8 Test and examine safety equipment.....	62



Table of contents	Page
7 Cleaning. Maintenance.....	63
7.1 Maintenance intervals.....	63
7.2 Maintenance	63
7.3 Cleaning	63
7.4 Checks	64
7.5 Special tools	64
7.6 Preventive maintenance	64
7.7 Corrective maintenance.....	65
8 Troubleshooting, error messages.....	66
8.1 Safety regulations.....	66
8.2 Indicate and correct faults	66
8.3 Error messages and troubleshooting.....	66
9 General information	66
10 Safety equipment.....	67
11 Service by Mess- & Analysensysteme Golombek GmbH	68
12 Supplier's liability	68
13 Sub-supplier documentation	69
14 Declaration of conformity	70



1 Safety instructions

This operating manual contains important information on how to analyze films safely and economically.

1.1 Obligations and liability

- A basic requirement for the safe handling and fault-free operation of this device is knowledge of the fundamental safety instructions and safety regulations.
- This operating manual, including but not limited to the safety instructions therein, must be observed by all persons working on and with the device.
- In addition, accident prevention rules and regulations valid for the site of operation must be observed.
- The device has been built to the state of the art and in accordance with the generally accepted safety regulations. Nevertheless, can its use be dangerous for the operator or a third party, or impair the device or other material assets. Therefore, the device may be used only:
 - for its intended purpose;
 - And in good order and condition as regards the safety equipment.
- In case of malfunctions that may impair the device's safety the device must be shut off and the fault must be corrected; only then the device may be switched on again.
- Any warranty or liability claims for personal injury or property damage shall be excluded if resulting from one or more of the reasons listed below:
 - Use of device other than its intended use;
 - Improper installation, commissioning, operation and maintenance of the device.
 - Operation of the device with defective safety equipment or not appropriately applied or non-functional safety and protective equipment;
 - Non-observance of notes and instructions in this manual as regards transport, storage, installation, commissioning, and maintenance of the device;
 - Unauthorized changes to the machine;
 - Unauthorized changes to the performance or drive conditions of the device.
 - Poor inspection of device parts that are subject to wear;
 - Improperly performed repairs;
 - Improperly performed cleaning jobs (for example, high-pressure cleaning);
 - Disaster situations resulting from force majeure or acts of God.



1.2 Safety icons

In this operating manual, we use the following descriptions and icons for hazards:



GEFAHR

This icon indicates an immediate danger for life and health of a person.

Failure to observe such notes or instructions results in severe damage to health, including life-threatening injury or death.



GEFAHR

This icon indicates an immediate hazard through electric energy.

Failure to observe such notes or instructions results in severe damage to health, including life-threatening injury or death.



WARNUNG

This icon indicates possible dangers for life and health of a person.

Failure to observe such notes or instructions may result in severe damage to health, including life-threatening injury or death.



VORSICHT

This icon indicates possibly dangerous situations for persons or damage to property.

A failure to observe such notes or instructions may result in slight injuries or property damage.



NOTE!

Icon and note indicate tips for use and other useful information.



1.3 Hazard pictograms



Mechanical hazards, such as squeezing, shearing, friction, abrasion, etc.



Danger through motor-driven components. Body parts or pieces of clothing may be drawn in. Do not remove any protective covers.



Danger through electrical equipment on device.



Danger through hot media.



Combined hazards.



1.4 Mandatory action signs

You must wear personal protective equipment (PPE) when working on device.



Wear safety shoes!



Wear safety gloves!



Wear safety goggles!



Wear protective clothing!



1.5 Intended use

We can guarantee operational safety of this device/system only if used as intended. The device may only be used for analysing films within the limits defined below.

The device may be used for analysing films with the following properties:

Material	Resin-coated or varnished paper
Width	60 mm
Height	96 mm
Weight of raw paper:	30 g/m ² - 150 g/m ²

Only if these criteria are met the device is deemed used as intended.

Intended use also includes:

- Observance of all notes in this operating manual and
- Compliance with all inspection and maintenance requirements.



NOTE!

The device must not be used to analyse thermoplastic highly combustible films. This may result in danger for persons or damage to the device.

1.6 Inappropriate use

The device must not be used other than listed above because any inappropriate use may lead to risks for persons working on or near the device, who may incur injuries, or may cause damage to the device.

Heating of food or other objects (except for above films) is prohibited.

The operator alone bears the consequences of

- any not intended use;
- activities not described in this operating manual.

The manufacturer does not accept any liability for any damage resulting thereof. In case of not intended use, any liability claims to the manufacturer shall be forfeited.



1.7 Limitations of device

The device is suited for analysing films within the described temperature range and in the approved liquid:

- Use "**Silikonöl TYP 350 für Folienanalyse**" (Silicone oil type 350 for film analysis) only! Use of other silicone oils may lead to inaccurate results or damage the device.

Analysis is impossible or impaired:

- if inappropriate media are used.

1.8 Organisational measures

The operating company must provide the necessary personal protective equipment and such PPE must always be functional.

All existing safety equipment must be checked and examined regularly.

All employees must be advised of the risks at their workplaces regularly.

1.9 Safety equipment

- Before you start the device, all safety equipment must be correctly installed and fully functional.
- Any safety features may be removed only after shutting down the device by specialised personnel, for maintenance, cleaning or repair purposes.
- If device components are shipped or fitted later on, the safety equipment must be attached by the operator in accordance with instructions.

1.10 Informal safety measures

- This operating manual must be kept at a place where it can be consulted at any time.
- In addition to the operating manual, all general and local regulations as regards power supply, accident prevention, operational safety and environmental protection must be provided for reference and complied with.
- All safety instructions and hazard warnings on the machine must be kept legible and must be replaced if necessary.



1.11 Safety measures in normal mode of operation

Operate the machine only if all safety equipment is fully functional. Prior to switching on, make sure that no person is at risk through starting device.

In regular intervals, the device must be checked for any visible damage and for the safety equipment's proper functioning.

1.12 Hazards through electric energy

- Only skilled electricians are authorized to carry out work on the electric system.
- Electrical equipment of the device must be checked regularly.
- If there are any defects on the electrical equipment, the device must be switched off immediately and the defect must be repaired by a skilled electrician.
- The device must only be started again after the electrical equipment has been checked and found faultless.

1.13 Specific hazards

- Squeezing and shearing hazard at individual device parts.
- Voltage hazard and risks at electrical equipment.
- Use of hazardous materials.

1.14 Preventive and corrective maintenance, troubleshooting

- Carry out prescribed adjustment, preventive and corrective maintenance as scheduled.
- All operating media such as electric, heating and drive systems must be secured against unintended start.
- While preventive or corrective maintenance jobs or repair jobs are carried out on the device, it must be fully de-energised and the main switch must be secured against unauthorised switching on.
- Upon completion of maintenance work and prior to switching on again, check correct function of safety equipment.



1.15 Cleaning of device and disposal

Used supplies and materials must be properly handled and disposed. This applies, including but not limited to:

- the cleaning of the device;
- and when replacing parts.

1.16 Device noise

- The noise emission level of the device is < 50 dB(A) (DIN EN 60704-1).

1.17 Accident prevention regulations, industrial safety regulations

- All applicable accident prevention regulations and industrial safety regulations must be complied with at any time.
- In case of any accident or failure, the device must be shut off at the main switch immediately.



2 Device description, technical data

2.1 Overall view device for film analysis

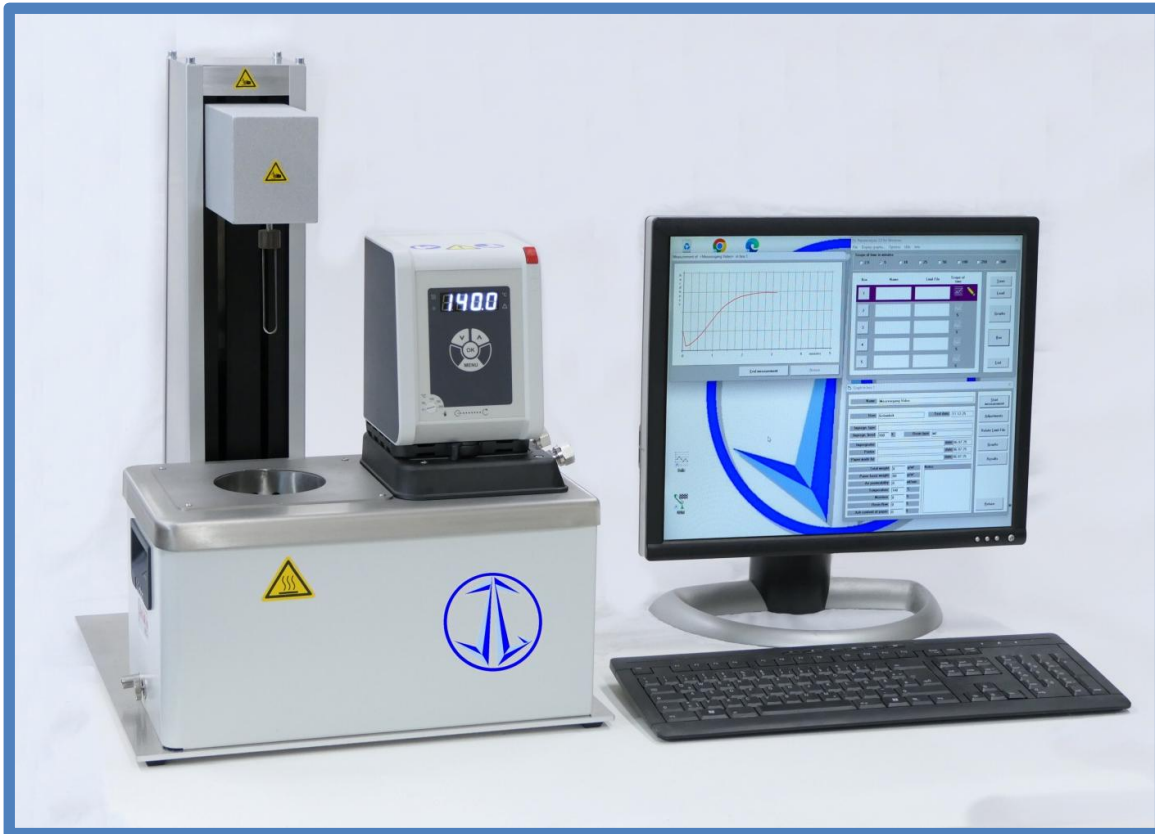

Image 1 Complete device

2.2 Workplaces

The device must be used by a single person only. The workplace is at the front side of the device.



NOTE!

The device operator must take care that the workplace is free of any objects that may represent risks.

2.3 Hazard zones

All hazards in connection with the device are listed in the risk assessment and the necessary measures for avoiding hazards have been carried out.

However, there may still be residual risks in connection with the device. Therefore, all safety instructions and warnings in the operating manual and on the device must be noted and observed in any case.



2.4 Device labelling



Figure 1: __Type plate with CE marking



2.5 Technical data

General data	
Device L x W x H (mm)	450 x 450 x 600
Weight:	approx. 30 kg

Table 1

Power supply / electrics	
Operating voltage	AC 230V, 50Hz optional AC 120V 60Hz
Main fuse	16 A delayed

Table 2

Process data			
Duration of analysis:	2.0 – 30 minutes		
Supplies (approx.)	Silicone oil		

Table 3

Environmental conditions	Operation
Room	The device must be operated indoor only, in a frost-free room. The device must not be used in potentially explosive environments.
Temperature	min. 5 °C, max. 40°C
Humidity	max. of 90 % relative humidity

Table 4

Environmental impact	
Noise level at device	< 50 dB(A) (DIN EN 60704 – 1)

Table 5



3 Design and function of device

3.1 Mechanical design and legend

Figure 2:







4 Transport and storage

4.1 Means of transport

A suitable jack lift is required for device transport.
Such jack lift must be suited for the device's weight and dimensions.
(For this, see section "Technical data").

4.2 Safety instructions for transport

 WARNING	
	Falling Load Hazard
	May result in severe injury and property damage.
	Lift up or transport machine only using lifting gear that is suited for the weight and dimensions of the device. <ul style="list-style-type: none"> ▪ Mind information in technical data. ▪ Do not transport device using a crane. ▪ Do not incline device during transport. Due to its high centre of mass, the device may tilt over easily. ▪ Make sure to balance the centre of mass during transport. ▪ Do not reach under the device while putting down the load.

 WARNING	
	Transport, dismantling and assembling of device by skilled and trained personnel only.

4.3 Preparing for transport

1. If the device has been operated already, it must be decommissioned prior to transport. Liquid in bath must be cooled down and filled in a suitable container.
2. Check condition and load bearing capacity of intended installation location and of entire transport path.
 - Install device on plane and stable base only.
 - Observe all local applicable regulations for working rooms.
 - Take note of all technical data of device.
3. Determine and mark exact installation location.
4. Determine transport path and remove any obstacles.
5. Keep away unauthorised persons from transport path and installation location.
6. Close areas, if necessary.



4.4 Transport original packing

Observe the safety instructions in chapter 4.2 and the loading and transport instructions on the device!

For transport by truck, be sure to choose a safe location and fix the device safely on the platform.

Upon arrival, check device for any obvious transport damage. If you notice any defect, report it to the carrier immediately.

The device is shipped in its original packing, on a pallet or in a crate, and it should stay that way as long as possible on its way to its installation location.

The device must not be turned over or inclined by more than 5° horizontally.

For the device's gross weight including original packing, see Technical Data section of this operating manual.

4.5 Transport unpacked

- See and observe safety instructions in chapter 4.2!

Requirements

- No liquid in device.
- Main switch switched off and any energy supply disconnected.

Procedure

1. Check and secure transport path, and remove any obstacles.
2. Carry all components to installation location individually, one by one.
3. Transport of device to its installation location should be as close as possible to the floor.
4. Put down device slowly and carefully. In doing so, do not reach underneath the load.



5 Installation and commissioning

5.1 Install device



The device must not be operated in a potentially explosive environment or where there is a risk of frost.

NOTE!

Its analysing performance is heavily limited with an ambient temperature of less than 15°C. Chose a suitable installation location.

Do not operate the device in an environment in which, for example, acids are used to clean other parts. Various acids may cause pitting corrosion on device parts.

Prerequisites



The device's installation location must be sufficiently stable, clean and plane.

All local applicable safety provisions and regulations must be complied with.

Procedure

- 1 Place device at its final location. For this, also see transport instructions in chapter 4.6.
- 2 Device must be leveled out in all directions.

5.2 Connect to power supply

 DANGER	
	Electrical hazard
	This may result in fatal electrocution.
	<ul style="list-style-type: none"> ▪ Connect electrical connections in accordance with the wiring diagram and the information on the type plate. ▪ Device must be connected to power supply outlets with isolated ground receptacles (PE) only! ▪ The mains plug serves as safe separation from mains. ▪ and must always be freely accessible at any time. ▪ Do not operate device with damaged power cord. ▪ Power cord must be regularly inspected for damage. ▪ No liability accepted in case of improper power connection! ▪ In accordance with all valid standards at the installation location, for example VDE 0100, this may be done by a skilled electrician only.



Power supply

Note and observe information regarding power supply on the device's type plate and in wiring diagram.

Before connecting to power power supply, check and observe the following:

On the building side, use delayed-action fuses only and an earth leakage circuit breaker (ELCB) with a tripping current of 30 mA max.

On the building side, install a suitable line disconnecter before the plug connection.

Check voltage. PE and neutral line must be dead!

Check through connection of protective earth conductor system!

5.3 Supplies

Oils approved by Mess- & Analysensysteme Golombek GmbH

Silicone oil	▪ "Type 350 for film analysis" from Mess- & Analysensysteme Golombek GmbH



Use of other chemicals

Mess- & Analysensysteme Golombek GmbH does not accept any liability for property damage resulting from the use of non-approved chemicals.

Mess- & Analysensysteme Golombek GmbH may approve other chemicals on request.

Any costs incurred for such approval Mess- & Analysensysteme Golombek GmbH will be charged.



 WARNING	
 	<p>Hazardous Materials!</p>
	<p>There is the risk of harmful reactions on skin, mucous membranes and eyes and property damage.</p>
	<ul style="list-style-type: none"> ▪ When handling hazardous materials, it is essential to observe manufacturer's safety instructions in the safety data sheet. ▪ Wear eye and skin protection when handling hazardous materials. ▪ Do not eat, drink or smoke while working with it. ▪ Bind any spilled oil using adequate agents. ▪ Observe all notes regarding proper disposal of residual amounts and containers.

5.4 Commissioning

Carry out commissioning steps when you use the device for the first time or after it had been out of operation for a longer period of time (> 3 months).

 WARNING	
	<p>First-time commissioning by specifically trained and instructed skilled personnel only. Observe operating manual and safety instructions of device and safety data sheets of supplies!</p> <p>Do not operate device with protective enclosures or safety covers dismantled!</p>

5.5 Preparations

Procedure

1. Switch off main switch.
2. Banish all unauthorized persons from the device area.
3. If necessary: Clean device.
4. Check the complete device visually.
5. Check energy supply.
6. Check fill level of bath liquid (next page).



NOTE!



Fluid level in the bath:

For guidance, the silicone oil level at room temperature should be approximately 5 mm below the holes in the bath insert.

Due to the thermal expansion of the oil, at 140°C the level should be between halfway down and the top edge of the holes. Precise adjustment of the level can be made once the bath is heated.



Level for filling
at room temperature.



Minimum level when
the device is heated up



Maximum level when
the device is heated up



5.6 Switch on device and check function



Turn on power switch on heating unit. Once the display reads "OFF", the tempering bath may be put in operation by pressing the OK button. Please also read the relevant notes in the JULABO manual.

6 Operation of device

6.1 Computer-aided measurement

Please also read the relevant safety instructions in the JULABO manual!

After starting the film analysis program that runs in a Windows environment, an idle measurement is carried out automatically in order to allow zero suppression. For this, pay attention not to touch or even block the specimen holder of the measuring unit during this calibration process.

During idle measurement, the following screen is displayed:



As soon as idle measurement is completed, the program displays the main screen.

The program is now ready for operation. To start measuring, a specimen must be fitted to the measuring head.



6.2 First measurement

To make a measurement, you will need a specimen.

For this, you need the supplied punch and the steel rule.

Punch out a piece of film for measuring.

For this, place the steel rule on the film and insert both between the two thrust plates of the punch. Press down the lever to punch out the specimen.

The size of the punched film specimen is 96 x 60 mm.

Always note the orientation of the film fibres.

Make sure that the fibre orientation of the specimen is always in direction of the stir head.

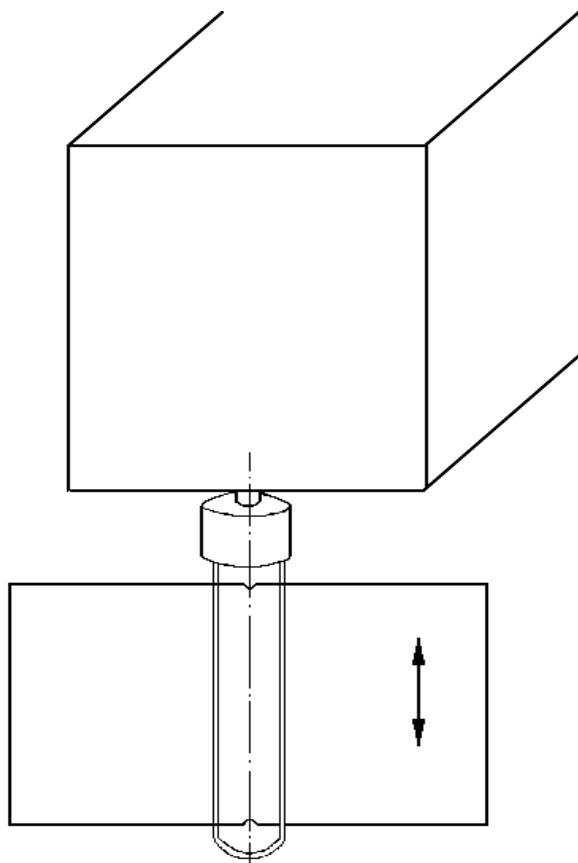

The paper's fibre orientation has certain influence on the measurement. In order to guarantee comparability of the measurements, you should always punch out specimens with the same fibre orientation.

After preparing the specimen as described above and after calibration is complete, you may fix the specimen in the wire fork.



CAUTION	
	Risk of trapping or drawing in of body parts by stirrer fork.
	Body parts may be injured or crushed.
	<ul style="list-style-type: none"> Safety equipment (for example, fix covers) must be installed. These must not be removed, bypassed, circumvented or put out of operation. Defective protective or safety equipment must be replaced immediately. Device must be switched off and secured until protective or safety equipment is replaced or installed. Do not touch any rotating parts!

WARNING	
	High temperature hazard in tempering bath (200°C)
	Risk of significant burns or scalding of skin or eyes!
	<ul style="list-style-type: none"> Do not reach into tempering bath! Avoid splattering of tempering fluid! Wear safety goggles! Wear heat-resistant gloves!

Make sure that the specimen is positioned exactly in the middle of the fork.
For orientation, you may use the punched slots in the specimen.



The screen now shows the main screen:

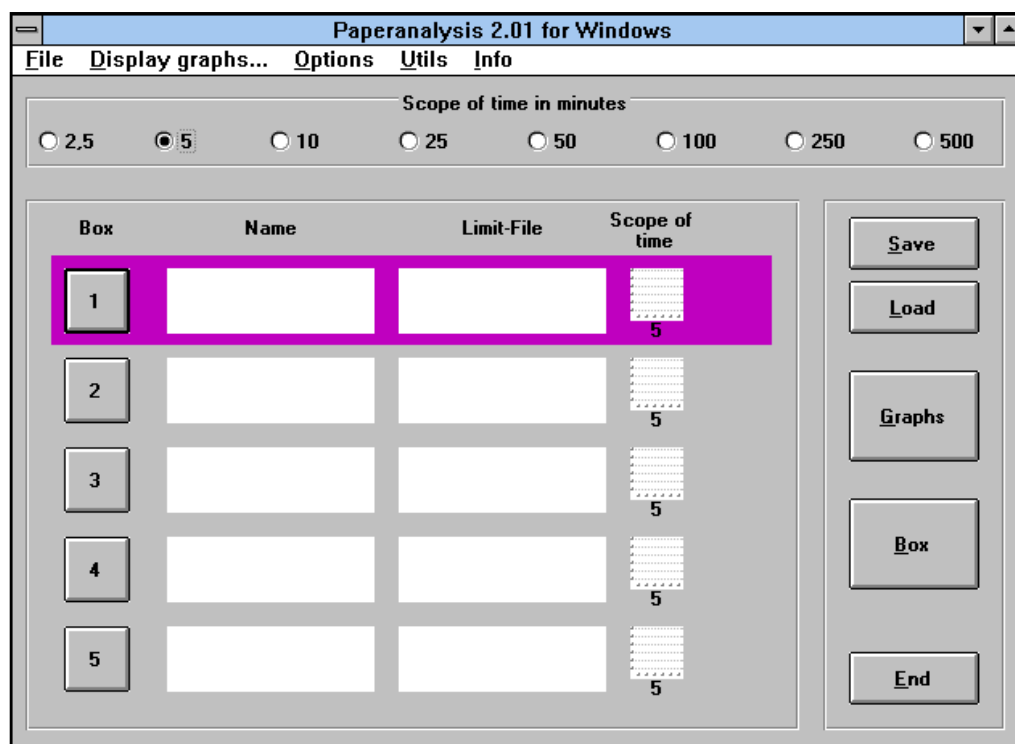

The main screen shows 4 areas:

- Menu bar
(File, Display graphs ..., Options, Utils, Info)
- Buttons for setting the current scope of time
(2.5 5 10 25 50 100 250 500)
- Overview of 5 available boxes
including enabling buttons (1 ... 5)
- Function buttons
(Save, Load, Graphs, Box, and End)

We would now like to guide you through the program as you proceed with the measurement as follows:

Box: A box can be seen as a container into which a graph can be loaded from the hard disk or where a new graph can be created based on a measurement. At any given point of time, there will only be one active box. Most buttons or menu items relate to activities within the active box.

After starting the program, the first box will be enabled. This is indicated by the violet highlighting.



To enable a different box, move the cursor to the desired button (1 - 5) and click the left mouse button.

Now, if another box is active, enable box 1.

To open the active box, move the cursor to the **Box** button and do a left-click.

The Box window will be displayed:

The screenshot shows a software window titled "Pattern in box 1". It contains the following fields and buttons:

- Name:** [Text input field]
- User:** [Text input field] **Test date:** 08.03.95
- Impregn. type:** [Text input field]
- Impregn. level:** 0 % **Resin type:** [Text input field]
- Impregnator:** [Text input field] **date:** [Text input field]
- Printer:** [Text input field] **date:** [Text input field]
- Paper made by:** [Text input field] **date:** [Text input field]
- Total weight:** 0 g/m²
- Paper basis weight:** 0 g/m²
- Air permeability:** 0 ml/min
- Temperature:** 140 °C
- Moisture:** 0 %
- Resin flow:** 0 %
- Ash content of paper:** 0 %
- Notes:** [Large text area]
- Buttons (right side):** Start measurement, Adjustments, Relate Limit-File, Graphs, Results, Return

For statistical reasons and for archiving your data, you should try and complete this screen as good as possible.

Enter a film or graph name into the Name field. This will be the name under which the graph is stored on the hard disk.

To get to the next field, hit the **Tab key** or move the cursor to and left-click on the desired field. To get to the former field, hold down the **Shift key** and hit the **Tab key**.

Within a field, you may move around using the arrow keys (arrow left/right).

If there is an error in the field, you may delete it by hitting the **Del key** or the **Backspace key**.

It is essential that you enter the correct value in the **Paper basis weight** field.

The program needs this value to calculate correctly. If the **Paper basis weight** field remains blank, the program will assume a raw weight of 80g/m².

Once you've filled in all fields correctly, click on the **Start measurement** button (upper right corner of box screen).



The screen now shows the measurement screen:

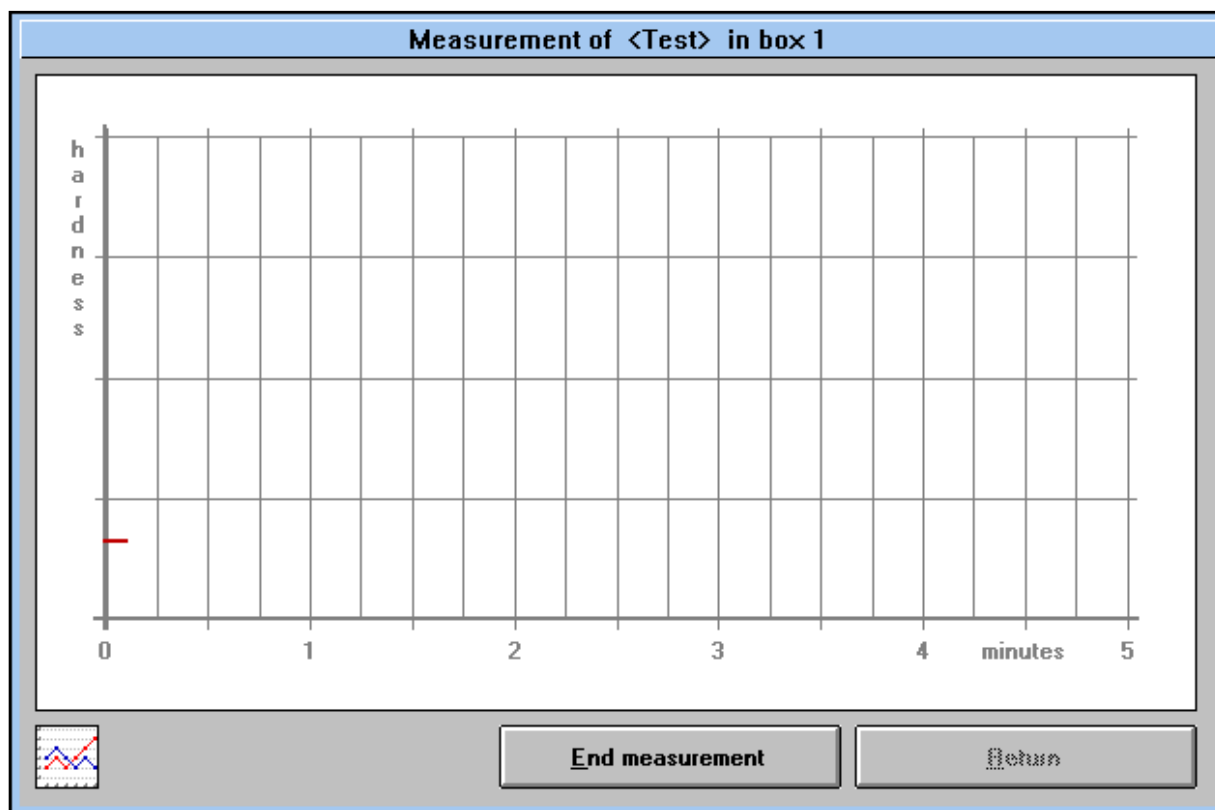

The measurement screen shows a coordinate system where the x-axis shows the time in minutes and the y-axis the hardness.

The measuring head and the specimen now sinks into the silicone oil bath that was heated to 140°C.

The measuring process can be tracked on the screen directly.

If, after a specific time period as set in the program, the graph does not continue any longer, the measuring process can be cancelled by clicking the **End measurement** button. The measuring head, together with the cured specimen, returns to its initial position.



By clicking the **Return** button you will return to the main screen:

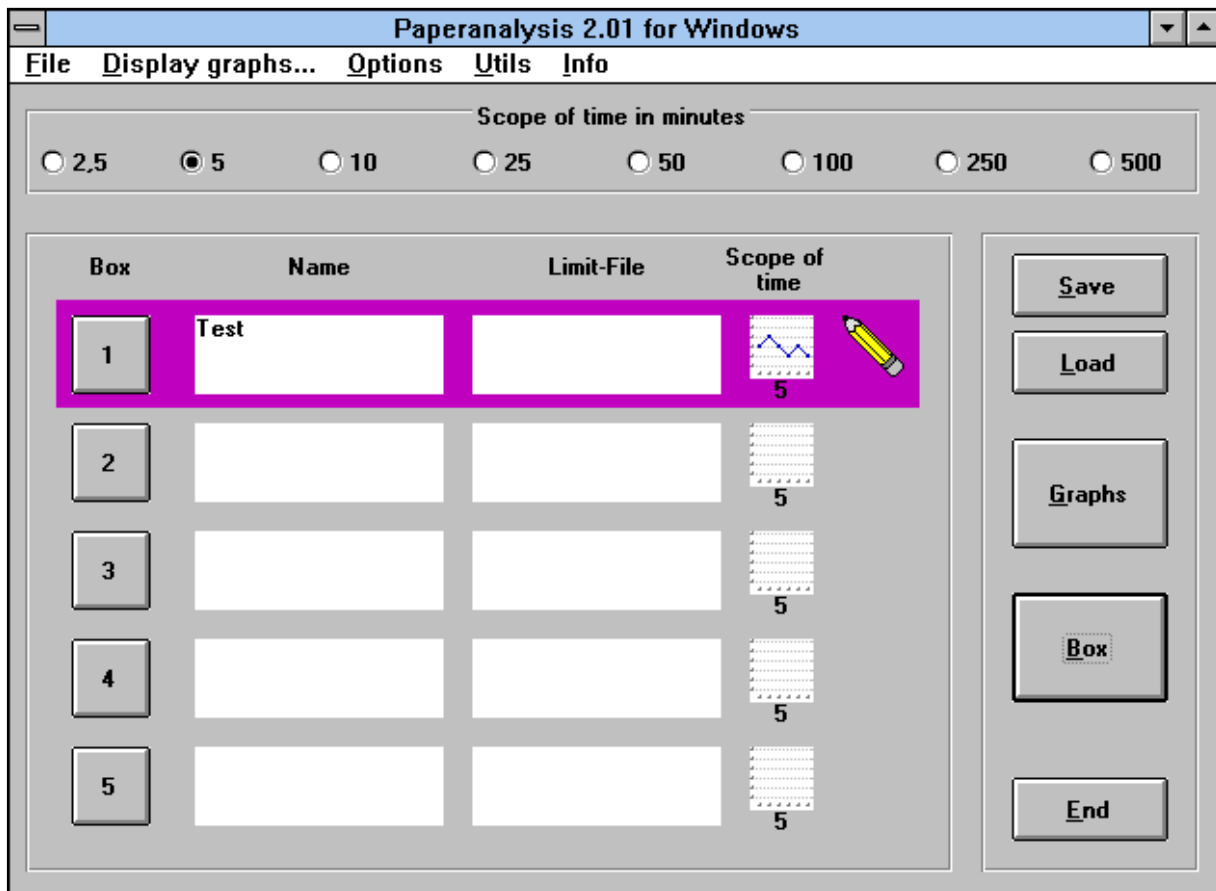

The box overview now shows:

- Name of the graph
The graph name is the name you previously entered in the box screen.
- A graph in the scope of time grid
that means that the box contains a measured graph that was measured within the scope of time that is indicated just below the grid.
- A pen
that means that box data was edited but not yet saved to the hard disk.



To display the measured graph on the screen or to print it, click on the **Graphs** button.

The Display Graphs screen appears:

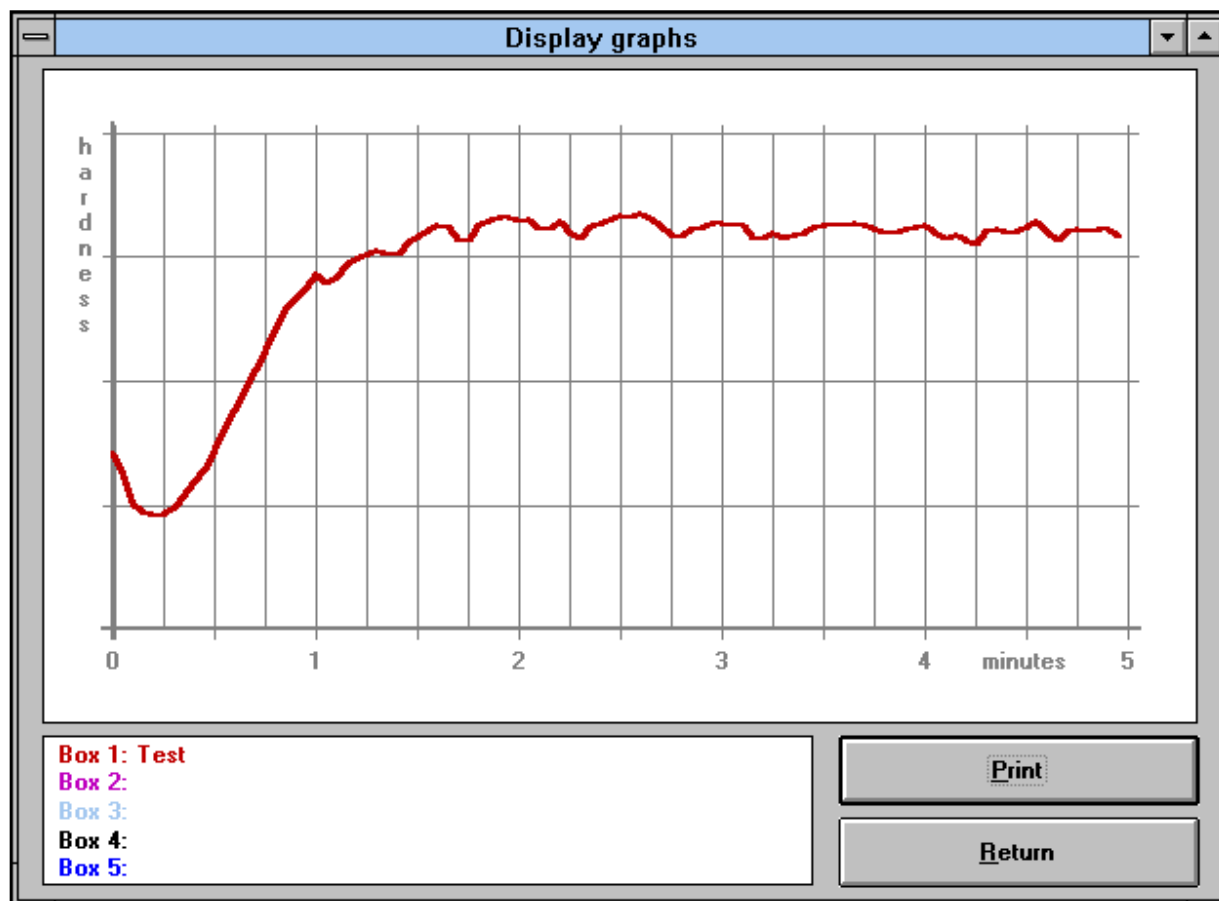

You would now like to print the graph and the calculated data.
Check if your printer is switched on and check for paper.

Click the **Print** button; a dialog window will appear prompting you to confirm **Print graph?** by clicking **Ok**.

By clicking the **Return** button you will return to the main screen.



In order to save the graph in the current box to your hard disk, click the **Save** button in the main screen.

The screen now displays the Save screen:

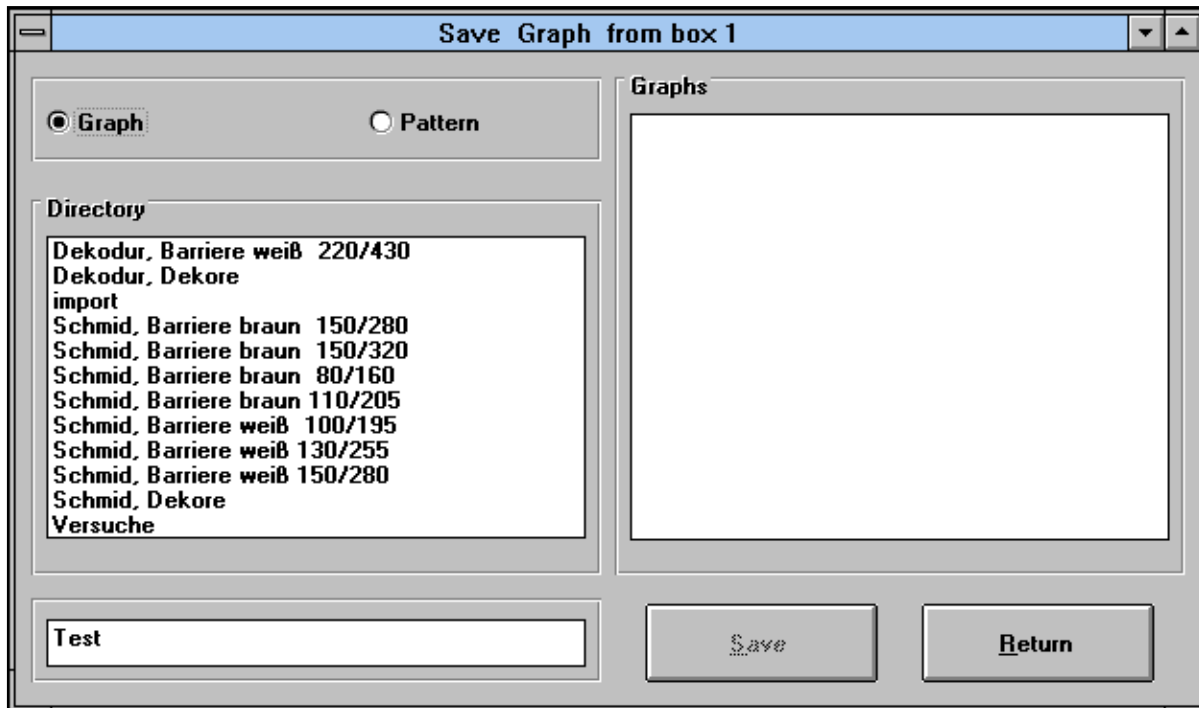

The Save screen includes two list boxes:

- a) Directory list box
It lists all directories in the program.
- b) Graphs list box
It displays all graphs included in the selected directory.

In order to save the measured graph under the name displayed in the field located in the bottom left corner, click on the directory in the directory list box in which the graph is to be saved.

Now, the graphs list box displays all graphs included therein and the **Save** button becomes active.

By clicking the **Save** button, the graph is saved and you will return to the main screen automatically.

The main screen will not show a pen any longer in the box overview, that means that the measured graph has been saved.



6.3 Program description

6.3.1 Basics

Box: A box can be seen as a container into which a graph/pattern can be loaded from the hard disk or where a new graph can be created based on a measurement. Most of the activities triggered by buttons or menu items relate to the active box.

Graph/pattern: If the same settings, limits or specimen data are used for different graph measurements, such data may be entered into a box and saved as a pattern, as a basis for future measurements. So, a graph is just the same as a measured pattern.

6.3.2 Main screen

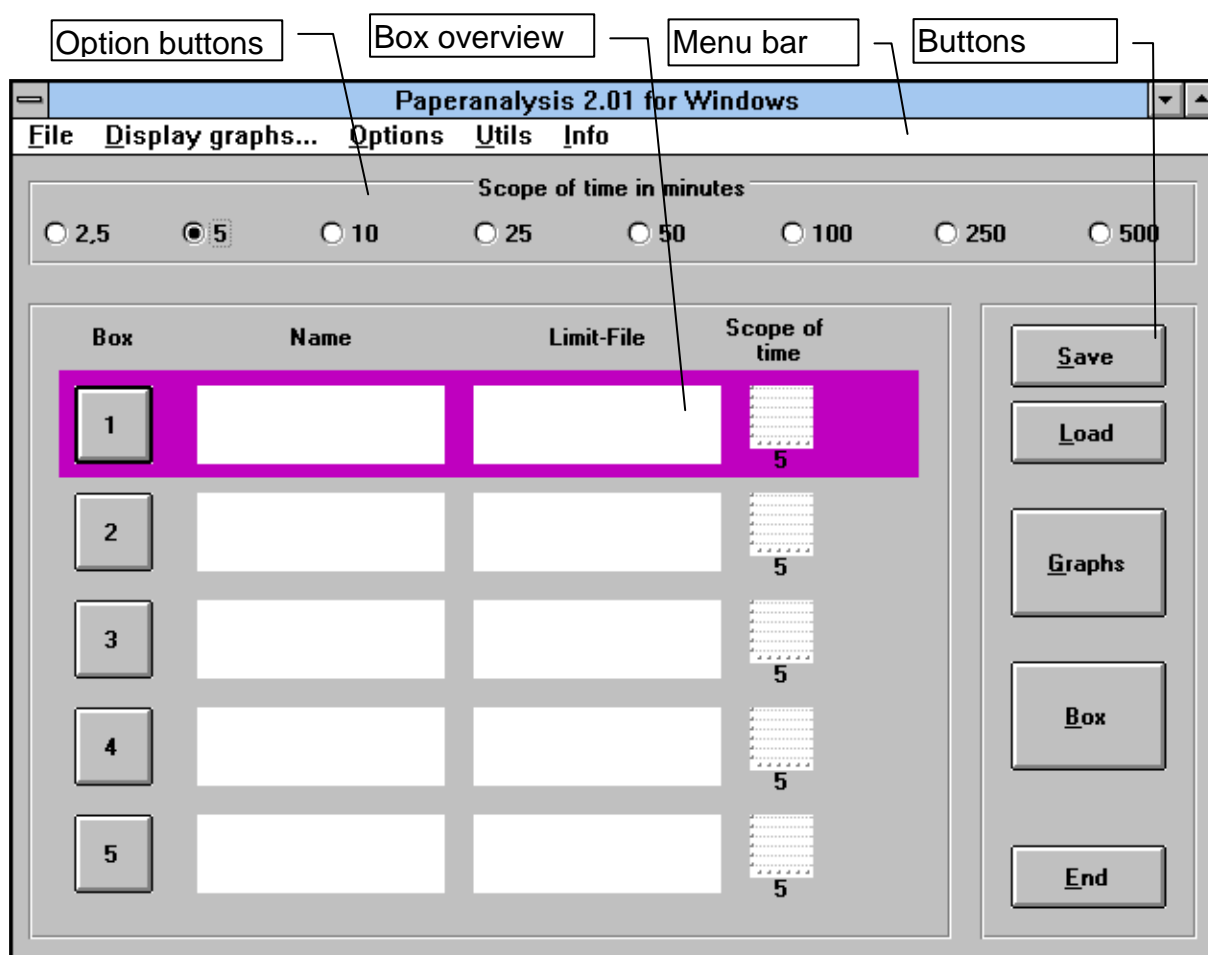

6.3.2.1 Buttons for setting the current scope of time:

The current scope of time is the period of time on which the graph measurement is based. However, if there is a graph in a box, the scope of time in which the graph was measured is maintained as the scope of time of the box, that means that there may be graphs with different scopes of time in the five available boxes.

If graphs are displayed by clicking the **Graphs** button, only such graphs are displayed whose scope of time is the same as the current scope of time.



6.3.2.2 Box overview

Five boxes are available in the program.
These boxes are enabled by clicking the relevant button (1 ... 5).

The box overview includes:

- a) Activation button
- b) Name:
Displays the name of the graph/pattern in this box.
- c) Limit file:
Name of assigned limit file.
- d) Scope of time and status
The scope of time corresponds to the current scope of time as long as there is no measured graph in the box.

The grid diagram of the scope of time shows whether a graph or pattern exists in the box.

Empty grid: A pattern is in the box.
Grid with graph: A graph is in the box.

- a) Pen:
A pen is displayed on the right side of the box overview, indicating not yet saved changes to graphs/patterns.

6.3.2.3 Button: Save

Saves a graph/pattern of the current box to the hard disk (see 3.4.).

6.3.2.4 Button: Load

Loads a graph/pattern from the hard disk to the current box (see 3.5.).

6.3.2.5 Button: Graphs

Clicking the Graphs button displays all graphs whose scope of time is the same as the current scope of time. (see 3.6.)

6.3.2.6 Button: Box

Clicking the box button opens the current box.

In the box, specimen data and measurement settings are entered/selected, measurements are carried out and results are displayed. (see 3.7.)

6.3.2.7 Button: End

By clicking the **End** button, you exit the program. If there are any unsaved graphs/patterns in any box, there will be a prompt to confirm.



6.3.3 Main screen menu

6.3.3.1 Menu item: **File > Save Graph/Pattern**

Saves a graph/pattern of the current box to the hard disk (see 3.4.).

6.3.3.2 Menu item: **File > Load Graph/Pattern**

Loads a graph/pattern from the hard disk to the current box (see 3.5.).

6.3.3.3 Menu item: **File > Delete Graph/Pattern in Box**

The graph/pattern of the current box is deleted; the specimen data and the measuring setting are reset to default settings.

The status of the current box after deleting corresponds to that of a box after program start.

6.3.3.4 Menu item: **File > Delete Graph/Pattern on Disk**

Delete a graph/pattern from the hard disk (see 3.8.).

6.3.3.5 Menu item: **File > Directory Create**

Create a new directory.

Allows creation of directories for saving limits, patterns and graphs. (see 3.9.)

6.3.3.6 Menu item: **File > Directory Delete**

Delete an empty directory.

Directories can be deleted only if they do not contain any files (limits, patterns, graphs).

If you want to delete a directory, you must first delete all files contained therein.

6.3.3.7 Menu item: **File > Limit Management**

This function allows assigning limits to results, before or after measuring a graph. (see 3.11.)

6.3.3.8 Menu item: **File > End**

Click on **End** in the file menu to exit the program. If there are any unsaved graphs/patterns in any box, there will be a prompt to confirm.

6.3.3.9 Menu item: **Display Graphs**

In the menu, click on **Display graphs** to display all graphs whose scope of time is the same as the current scope of time. (see 3.6.)

6.3.3.10 Menu item: **Options > Setup printer**

If you have several printers connected to your computer and would like to use a printer for the film analysis software that is not your default printer, this screen allows you to select your printer.

The **Printer setup** screen is a Windows screen and offers further setting options, depending on the printer driver.

For further information, see your Windows manual.



6.3.3.11 Menu item:Options > Graph colour

This option allows you to change the colour of the graph on the screen. First, select the menu item **Graph colour**. Another menu pops up, displaying existing boxes. Select the box, for which you would like to change the graph colour. In the colour dialog, you may now select the desired colour. Click **Ok** to confirm the change or **Cancel** to cancel colour change mode and then return to the main screen.

Note: Your graphic board may not support all of the colours offered. In such case, try another colour.

6.3.3.12 Menu item:Options > Other Settings

This option allows you to adjust to your needs the line thickness for printing and screen display and the margins for printing.

For adjusting the margins, you should note the following:

Your printer's physical margins are fixed. You can't print beyond those. The values you enter do not account for such physical margins; the margins of your print depends on your entered values and such physical margins. To determine the physical margins of your printer, set all margins to "0" and print a graph.

Click **Ok** to confirm the change or **Cancel** to cancel the change of settings mode and then return to the main screen.

6.3.3.13 Menu item:Utils > Reorganise database

When is a reorganisation of the database recommended?

- a) If error messages are displayed while reading or writing data from/to the hard disk, a reorganisation may be a remedy.
- b) Reading from / writing to the hard disk becomes time-consuming.
- c) After deleting many directories or data from the hard disk.

Note: **Before you carry out a reorganisation, we urgently recommend backing up your film analysis software!**

6.3.3.14 Menu item:Utils > Import graphs / patterns

The Import window allows you to import graphs or patterns created with the DOS version of the film analysis software. (see 3.15.)



6.3.4 Screen: Save

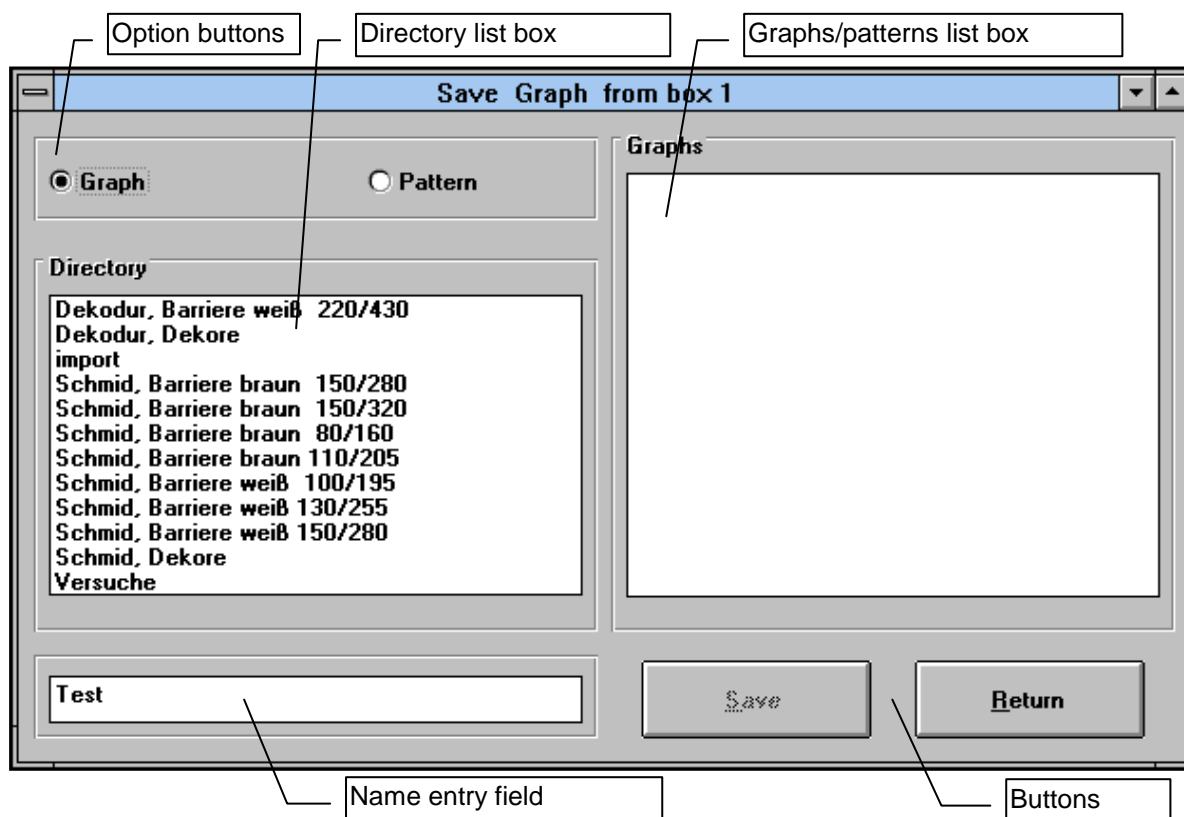

The **Save** screen has five sections:

- Option buttons: Graph/pattern
- Directory list box
- Graphs/patterns list box
- Entry field for name
- Buttons: Return & Save

The **Save** screen allows you to save a graph from a box as a pattern or as a graph on the hard disk. If there is a pattern in a box, such pattern may only be saved as a pattern on the hard disk.

Option buttons are used to select whether a graph is saved as a graph or pattern.

In the film analysis software, data is organised in a way that allows you to create custom directories for storing graphs or patterns.



If you select the pattern option button, for example, the directory list box displays all available pattern directories. The same applies for the graph option button.

If you highlight an entry (available directory) in the directory list box, the graphs/pattern list box shows all graphs/pattern stored in this directory.

If you load a graph or pattern from the hard disk into a box and change any data, but not the name of the graph/pattern, and you want to save it, the directory and the graph/pattern names are shown as default in the respective list boxes when the Save screen opens. If, however, you want to have another name for the graph/pattern, just enter the new name into the entry field (bottom left) and click the Save button.



6.3.5 Screen: Load

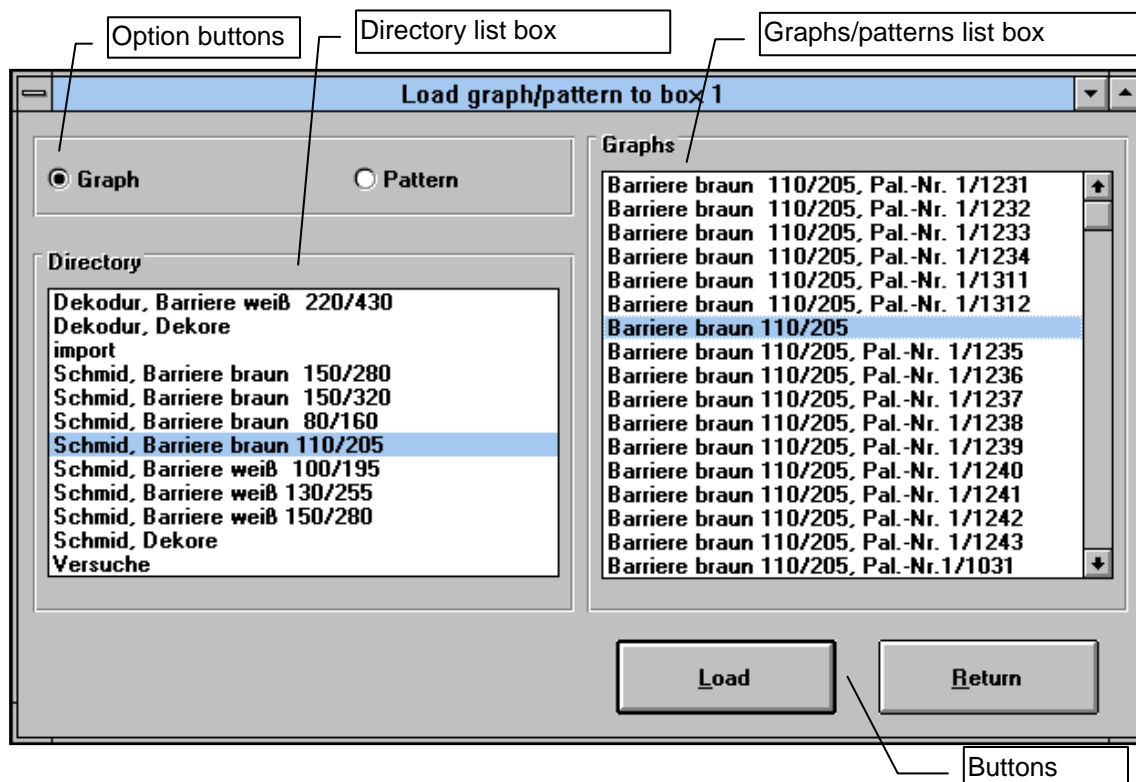

The **Load** screen has four sections:

- a) Option buttons: Graph/pattern
- b) Directory list box
- c) Graphs/patterns list box
- d) Buttons: Return & Load

The **Load** screen allows you to load a graph or pattern from your hard disk to one of the five available boxes.

In the film analysis software, data is organised in a way that allows you to create custom directories for storing graphs or patterns.

If you select the pattern option button, for example, the directory list box displays all available pattern directories. The same applies for the graph option button.

If you highlight an entry (available directory) in the directory list box, the graphs/pattern list box shows all graphs/pattern stored in this directory.

Now, to load a graph or pattern, select the directory and the desired file and confirm by clicking the **Load** button.

The **Load** screen closes and the current box displays the selected graph or pattern.



6.3.6 Screen: Display Graphs

The **Display Graph** screen allows you to display measured graphs on the screen and to print them on your printer.

The **Display Graph** screen shows a coordinate system where the x-axis shows the time in minutes and the y-axis the hardness.

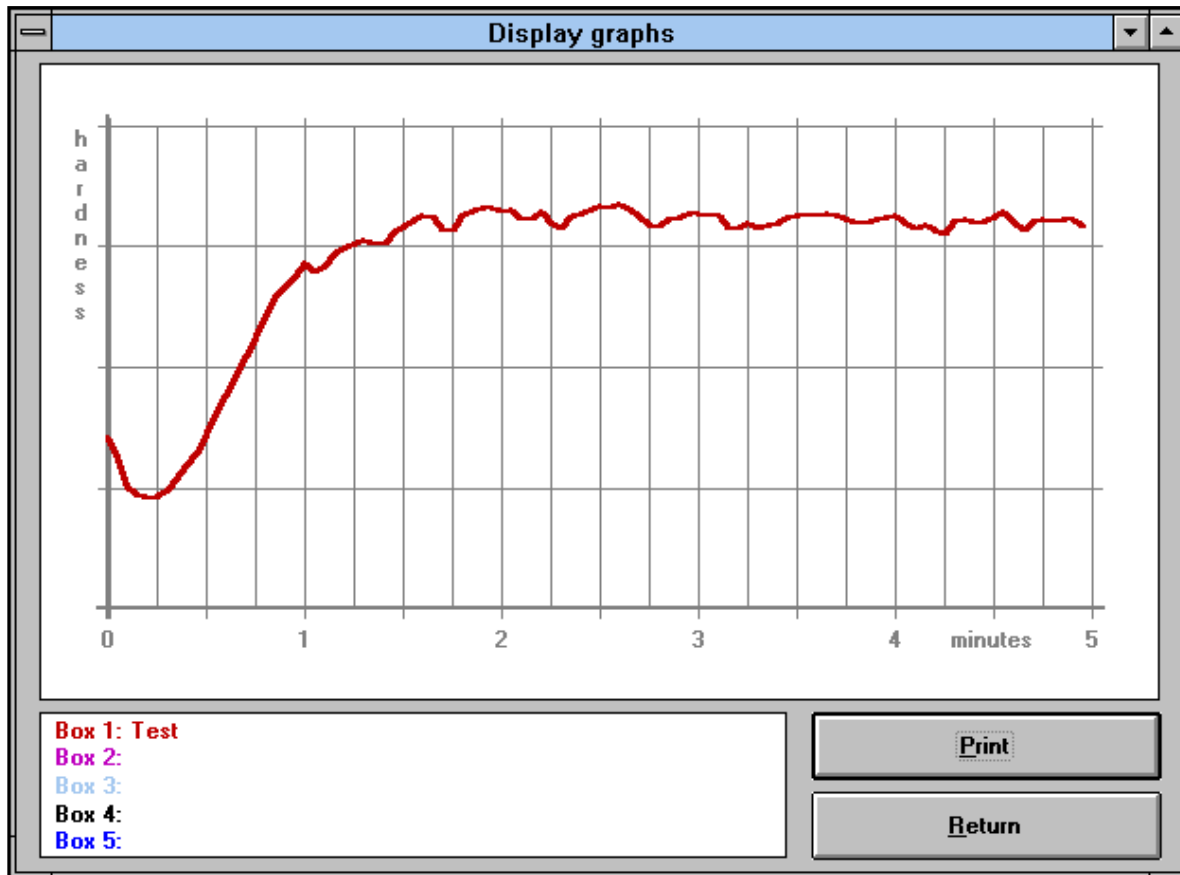

The Display Graph screen may be opened from the main screen or from the box screen.

Opening from the main screen, clicking the Graphs button will display all graphs whose scope of time is the same as the current scope of time. For better differentiation of the graphs, they display in different colours. The legend pane in the bottom left corner shows the respective names.

In the Options screen (menu item: **Options > Other Settings**), you can set the line thickness for screen display and printing.

The line colours are assigned to the boxes. The colour of a graph of a box may be changed under **Options > Graph colour**.

Opening the **Display Graph** screen from the **Box** screen will only show the graph that is currently in such box, irrespective of the current scope of time.

The displayed graphs will be printed by clicking the **Print** button and confirming the **Print graph?** prompt.



6.3.7 Screen: Box

Entry fields for specimen data

Name entry field

Buttons

Pattern in box 1

Name:

User: Test date: 08.03.95

Impregn. type:

Impregn. level: 0 % Resin type:

Impregnator: date:

Printer: date:

Paper made by: date:

Total weight: 0 g/m²

Paper basis weight: 0 g/m²

Air permeability: 0 ml/min

Temperature: 140 °C

Moisture: 0 %

Resin flow: 0 %

Ash content of paper: 0 %

Notes:

Start measurement

Adjustments

Relate Limit-File

Graphs

Results

Return

6.3.7.1 Entry field for graph / pattern name

The names entered here identifies the graphs and patterns when working with the film analysis program.

This name displays in the **Display graph** screen, on the print and in the box overview in the main screen.

When the graph is saved to the hard disk, this name is displayed as default. It can be accepted or overwritten by another name.

6.3.7.2 Entry field for specimen data

You can enter the respective specimen data into these fields.

This data, except for the paper weight, does not influence the measurement. However, for statistical reasons and for archiving your data, you should try and complete this screen as good as possible.

The Paper basis weight entry field is used for measuring. If no value is entered here, the program automatically assumes a paper weight of 80 g/m².

**6.3.7.3 Button: Start measurement**

Starts measurement, taking into consideration the current scope of time, the paper weight and the measurement settings (Adjustments). **Measurement** screen (see 3.12.).

If there is an already measured graph in the box, a prompt will pop up to prevent any accidental overwriting of the graph.

6.3.7.4 Button: Adjustments

Here you can set the measurement parameters.

In many tests and based on our experience with the film analysis device, these parameters have been exactly adjusted to the program. If, for any reason, you would like to change any parameters, see 3.13 for more details about the **Adjustments** dialog.

6.3.7.5 Button: Relate limit file

This function allows assigning limits to results, before or after measuring a graph. (see 3.11.)

6.3.7.6 Button: Graphs

Click the **Graphs** button to display the graph in the box. Click the **Print** button in the Display Graphs screen to print on the printer. (see 3.6.)

6.3.7.7 Button: Results

This shows the results, limits and limit deviation of the graph. (see 3.14.)

6.3.7.8 Button: Return

The **Return** button will get you back to the main screen.



6.3.8 Screen: Delete graph/pattern from hard disk

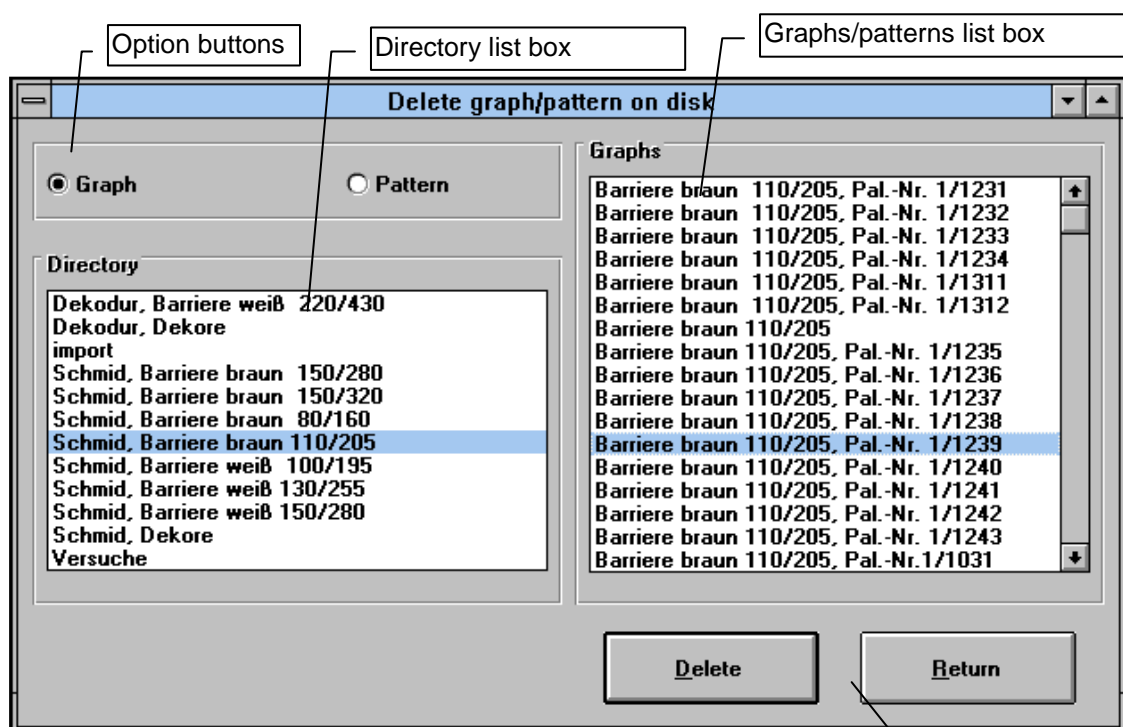

The **Delete** screen has four sections:

- Option buttons: Graph/pattern
- Directory list box
- Graphs/patterns list box
- Buttons: Return & Delete

The **Delete** screen is used to delete graphs or patterns from your hard disk, permanently.

In the film analysis software, data is organised in a way that allows you to create custom directories for storing graphs or patterns.

If you select the pattern option button, for example, the directory list box displays all available pattern directories. The same applies for the graph option button.

If you highlight an entry (available directory) in the directory list box, the graphs/pattern list box shows all graphs/pattern stored in this directory.

Now, to delete a graph or pattern from your hard disk, select the directory and the desired file and confirm by clicking the **Delete** button.



6.3.9 Screen: Create directory

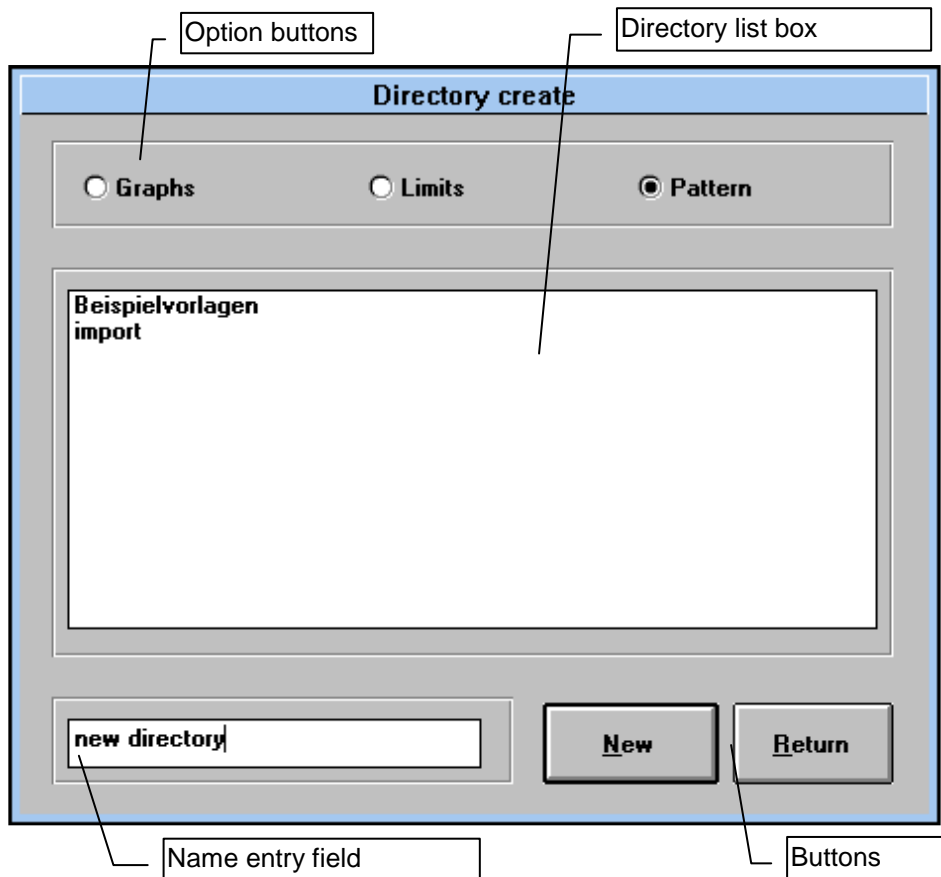

The **Create directory** screen has four sections:

- a) Option buttons: Graph / Limits / Pattern
- b) Directory list box
- c) Entry field for directory name
- d) Buttons: New & Return

The **Create Directory** screen allows you to create any directory for graphs, patterns or limits. After selecting the required directory type, the directory list box will display all directories already created for the respective type.

Enter the name of the new directory into the entry field and confirm by clicking the **New** button.

The directory list box will display the new directory and it will be available in data management for storing graphs, limits or patterns.

You can use the same names for directories of different types (graphs, patterns, or limits). The entry of names is case sensitive.

Clicking the Return button will get you back to the film window, without creating a directory.



6.3.10 Screen: Delete directory

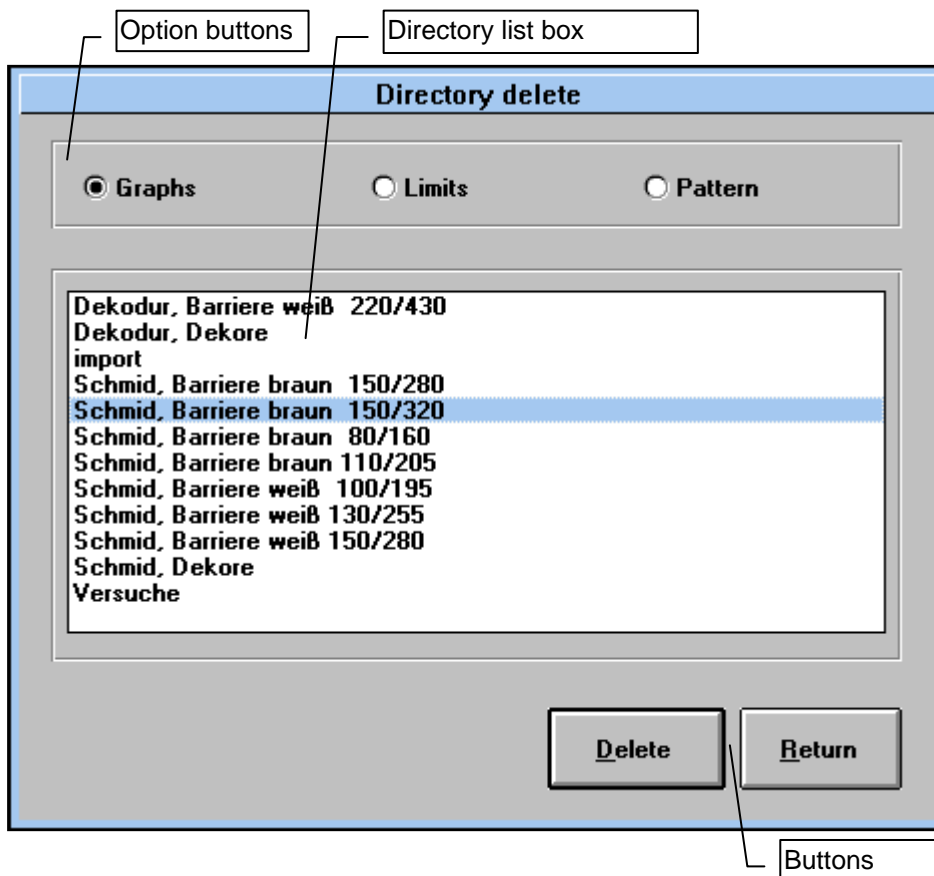

The **Delete directory** screen has three sections:

- Option buttons: Graph / Limits / Pattern
- Directory list box
- Buttons: Delete & Return

The **Delete Directory** screen allows you to delete any directory for graphs, patterns or limits.

After selecting the required directory type, the directory list box will display all directories of the respective type that exist in data management.

To delete a directory, highlight it in the directory list box and confirm by clicking the Delete button.

The directory will be removed from the directory list box and data management.

Clicking the Return button will get you back to the film window, without deleting a directory.

Note: A directory can be deleted only if the respective directory does not contain any graphs, patterns or limits any more.
Therefore, delete all files first that exist in the directory to be deleted.



6.3.11 Screen: Limit management

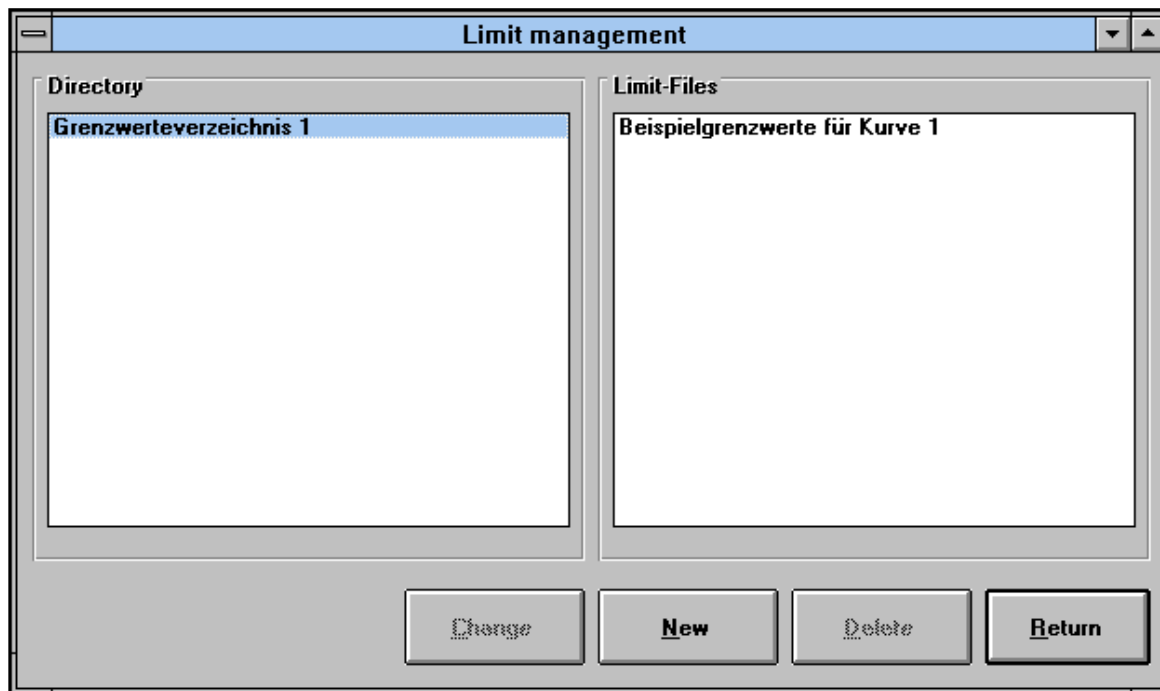

Limit management allows you to assign limits to graphs or graph results. Such limits must be entered and saved before they can be assigned. These limits are created in the program in form of a limit file. And limit files are stored in a limit directory.

Creation and deletion of limit directories is done in directory management.

Note: **Assigning a limit file to a graph does not assign the limit file as such, but only the limits and the limit file name. If, for example, an assigned limit file is changed or deleted, the limits of the graph will be maintained as long as the changed limit file is not reassigned.**

6.3.11.1 List box for directories and limit files

For creating a new limit file, select the directory from the directory list box in which you would like to store the new limit file.

For assigning, deleting or changing a limit file, choose the directory from the directory list box in which the limit file is stored and then, from the limit file list box, the required limit file.

Use the buttons described in the following for triggering the various functions.



6.3.11.2 Button: Assign

Once a limit file is highlighted in the limit file list box, it can be assigned to the current graph. The upper and lower limits and any deviations from the actual value are shown in the printout of a graph and in the results pane of the box screen.

6.3.11.3 Button: Change

Using the **Change** button, you may change the limits in a limit file. The **Change** button will be greyed out and not active until you highlight a limit file in the **Limit file** list box. After clicking the **Change** button, the limit management dialog box will appear.

	limit:			
	min.	max.		
Max. curing speed after:	1	120	(0...999.9)	min.
Curing time:	1,6	20	(0...999.9)	min.
Curing rate:	3,5	4	(0...9.999)	%/m
Flow time:	24	30	(0...9999)	sec.
Flexibility:	90	110	(0...999)	%

Cancel OK

Here, you can enter the limits for the calculated results of a graph.



6.3.11.4 Button: New

Using the **New** button, you can create a new limit file.
The new limit file can be stored in the directory highlighted in the directory list box. After clicking the **New** button, the following dialog box appears:

	limit:			
	min.	max.		
Max. curing speed after:	1	120	(0...999.9)	min.
Curing time:	1.6	20	(0...999.9)	min.
Curing rate:	3.5	4	(0...9.999)	%/m
Flow time:	24	30	(0...9999)	sec.
Flexibility:	90	110	(0...999)	%

Enter the required limits into the entry fields. Enter the name of the limit file into the **Name** field in the bottom left corner.

6.3.11.5 Button: Delete

Deletes a limit file from the hard disk.

Highlight the limit file to be deleted in the directory list box.

After clicking the **Delete** button, you will be prompted to confirm; after confirming, the highlighted limit file will be permanently deleted from the hard disk.

6.3.11.6 Button: Return

By clicking the **Return** button you will return to the screen from which you opened limit management.



6.3.12 Screen: Measurement

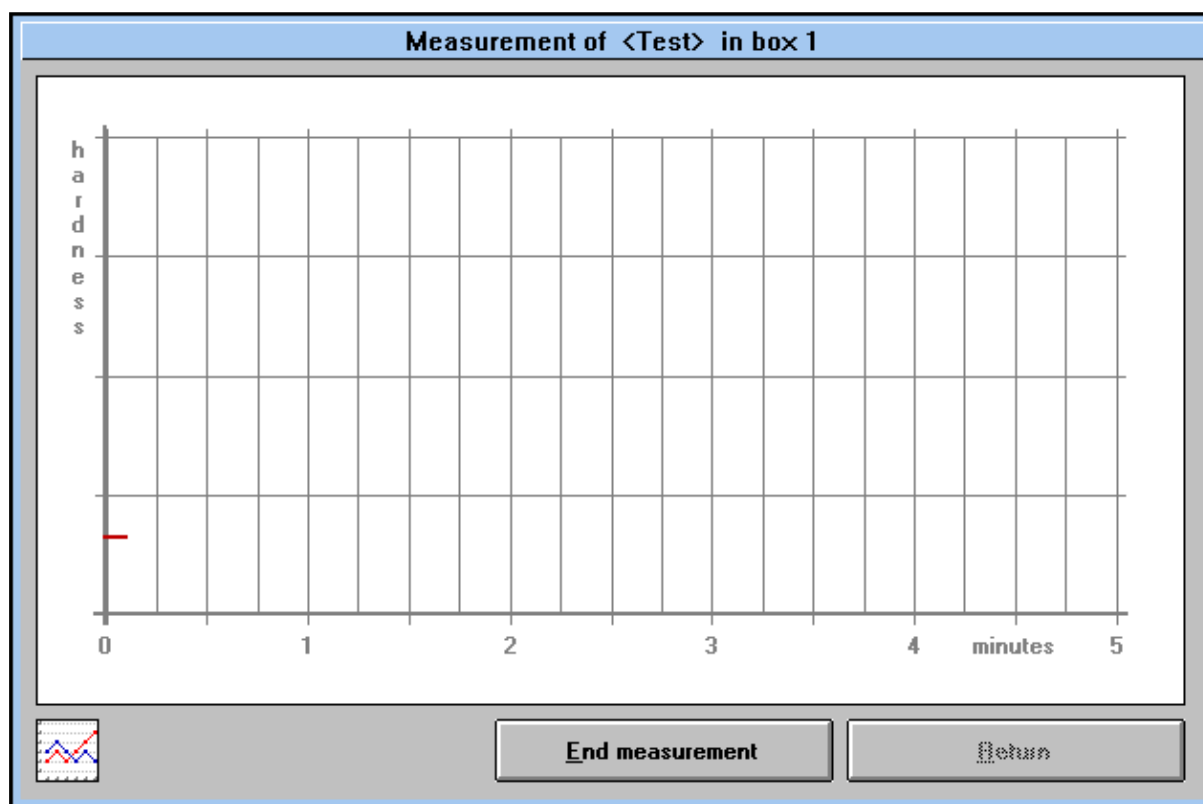

The measurement screen shows a coordinate system where the x-axis shows the time in minutes and the y-axis the hardness.

The time corresponds to the scope of time selected in the main screen.

You may stop a measurement early by clicking the **End measurement** button.

Clicking the **Return** button will get you back to the main screen of this film analysis program.

If a measurement is not stopped early, the window will close automatically upon the lapse of the total measuring time of the selected scope of time; the main screen will be displayed again.

Since the actual measurement is a time-critical process, it is impossible to start other Windows applications or switch to running applications while the **Measurement** screen is open.



6.3.13 Screen: Adjustments

Parameter	Value	Unit
Scope of time:	5	min
Specimen No.:	1	
Voltage:	8	V
Measuring cycle:	3	s
Oil viscosity:	350	m-Pa-s
Amplification:	100	%
Starting time:	.18	s
Measuring time:	.5	s
Open circuit current:	1.8575	mA

Buttons: Cancel, OK

The **Adjustments** dialog allows you to set the parameters required for measurement.

By clicking the **OK** button you activate the changed parameters and return to the **Box** screen.

Clicking the **Cancel** button will discard all changes made and the former settings (before opening the dialog box) will be the valid parameters.

In many tests and based on our experience with the film analysis device, these parameters have been exactly adjusted to the program. If, for any reason, you would like to change any of these parameters, we kindly ask you to note the effects listed below:

a) Stirrer number:

For specific applications, it may be necessary to work with a different measuring head; this can be noted in this field.

Default setting: No. 1

b) Voltage:

The voltage influences the rotational speed of the stirrer fork. Usually, you would want to use the default settings that had been calculated based on the raw paper weight. For specific test specimens or for experimental purposes, these default settings may be changed.

Possible values include: 2, 3, 4, 5, 6, 8, 10 Volts.

c) Measuring cycle:

The time interval between two stirrer fork rotations. For this setting, it is necessary to find a reasonable compromise between the number of measuring points, which are the result of each rotation, and the fact that the curing resin should be moved (disturbed) as little as possible to achieve a representative graph.



- d) Viscosity:
This is the viscosity of the test bath liquid at 20°C.
Default setting is 350 mPas for the standard silicone oil.
- e) Amplification:
If, for example, a specimen with differing dimensions is tested, it may be reasonable to adjust the graph height (curing axis) by this amplification value.
- f) Starting time:
In order to disregard the motor's starting current during measurement, the actual measurement of the motor's current drain begins only after the starting time.
- g) Measuring time:
After the starting time, the measuring time begins during which the current drain for rotating the specimen in the test bath is determined.
- h) No-load current:
Indicates the measuring motor's current drain under no load.

As soon as the program starts, the parameters will always be the default parameters. You can be sure that as long as you use these default settings, all measurements will produce reasonable results. We recommend always using these default parameters, except for experimental purposes, to guarantee comparability of measurements, yours and that of other users of the device.



6.3.14 Screen: Results

Results						
	results:		limit:		abberation:	
			min.	max.		
Max. curing speed after:	0,6	min.	0	0	0,6	min.
Curing time:	1,2	min.	0	0	1,2	min.
Curing rate:	5,1272	%/m	0	0	5,1272	%/m
Flow time:	21	sec.	0	0	21	sec.
Flexibility:	72	%	0	0	72	%

The **Results** screen shows the calculated results of a graph and the limits assigned to the graph.

If the result is within the minimum and maximum limits, deviation is 0.

If the result is above the maximum limit or below the minimum limit, deviation is calculated based on the difference between the actual value and the related limit.

The deviation's algebraic sign indicates whether the maximum limit is exceeded (positive) or the value falls below the minimum limit (negative).



6.3.15 Screen: Import graphs/patterns

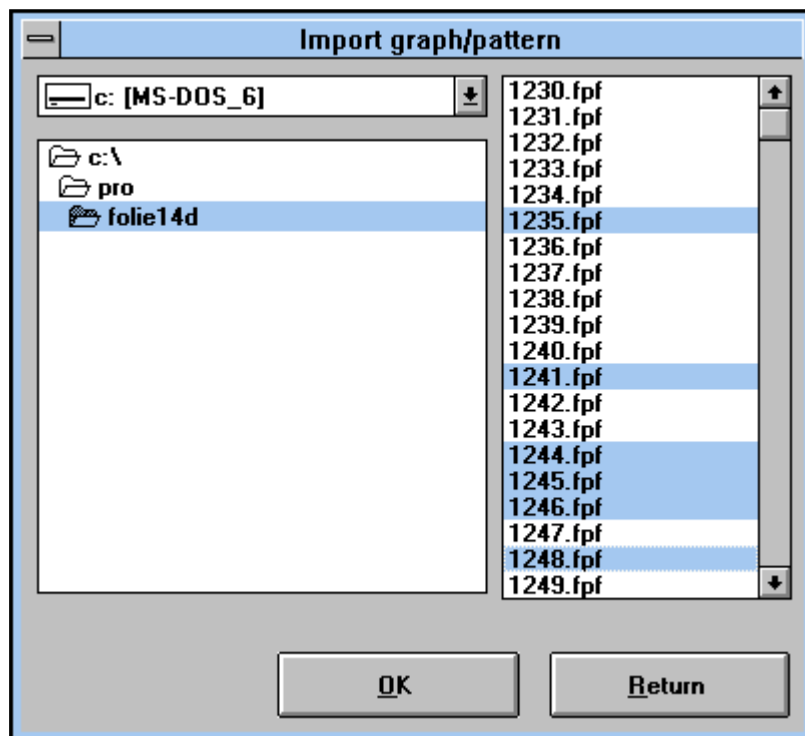

The Import window allows you to import graphs or patterns created with the DOS version of the film analysis software.

Imported files are stored in the Import directory. If such a directory is not existent, it will be created automatically.

The naming convention is: '*File name*'->'*Graph name*'

Measured graphs are stored as graphs in the Import directory; not measured graphs are stored as patterns in the Import directory.

6.3.15.1 List box for drives, directories and graph files

Use this list box to highlight the graph files you would like to import.

The **Graph file** list box offer several options for highlighting files:

- a) By clicking on the respective file:
The respective file is selected for import.
- b) By clicking on the first file and another click on another file while holding down the SHIFT key:
All files in between the two marked files are selected for import.
- c) By clicking on the first file and another click on a second file while holding down the CTRL key:
For selecting specific individual files for import. If several files have been selected, you can deselect a file by holding down the CTRL key and clicking on the file again.

Clicking on the **OK** button will start the import process.

Imported files may then be loaded to the desired boxes using the **Load** button.



6.4 Result analysis

6.4.1 Maximum curing speed after: [Minutes]

This means the point of time where the reactivity (gradient of the graph) is the highest.

This is the point of time that is identical to the turning point of the graph.

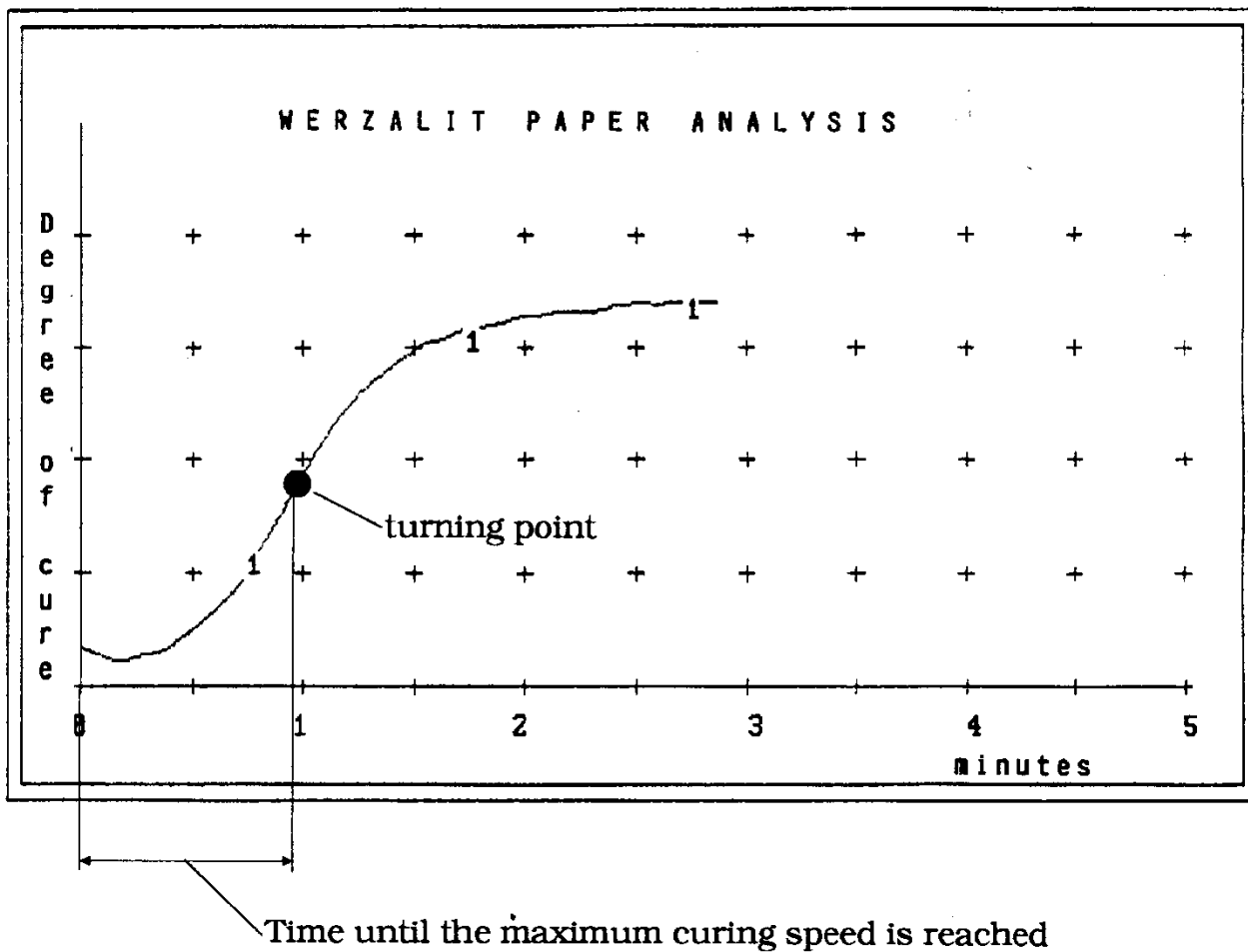



6.4.2 Curing time: [Minutes]

The curing time is the point of time where the graph has reached 95 % of the maximum hardness.

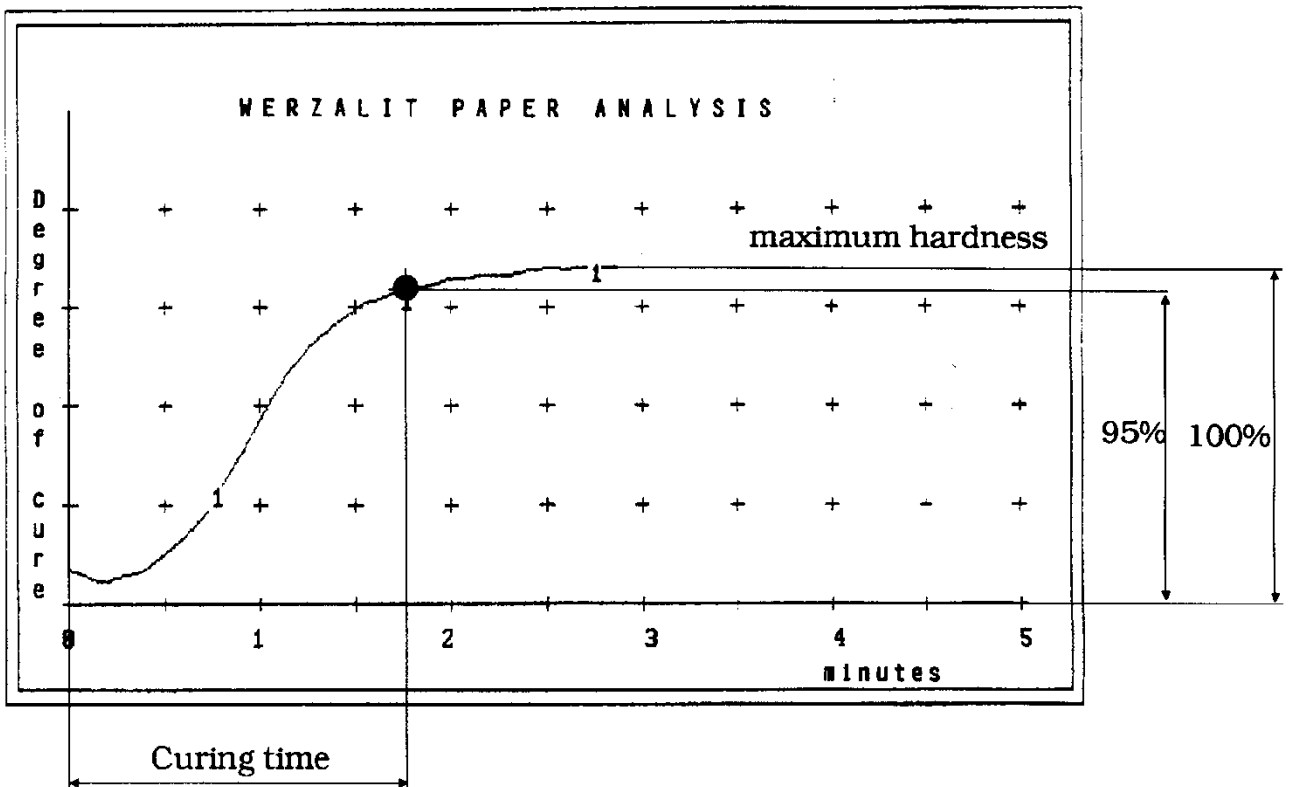



6.4.3 Curing speed

The curing speed indicates the maximum reactivity of the specimen.

Its value is calculated based on the maximum gradient of the graph that occurs at the turning point.

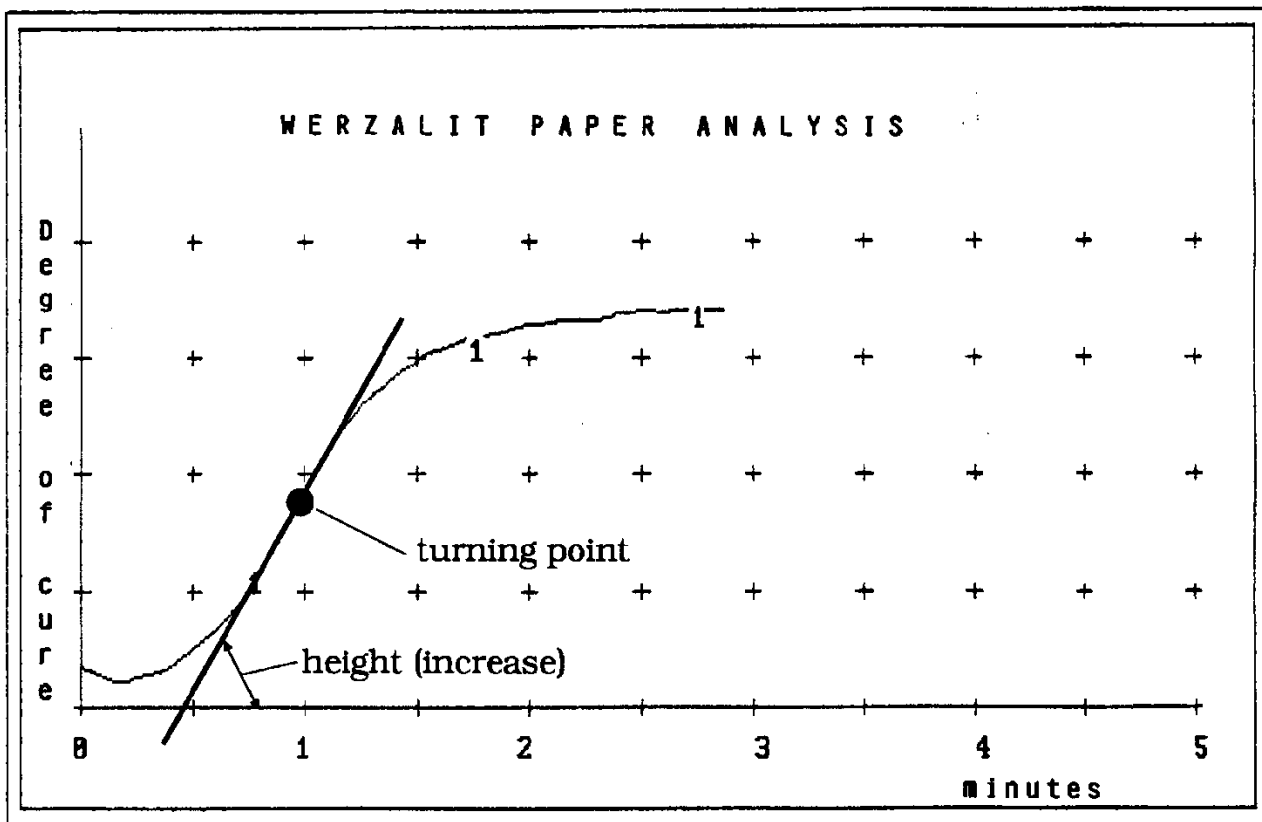



6.4.4 Flow time [Seconds]

The flow time is the period ending at the lowest point, where the graph exceeds the lowest point + 4 % of the maximum.

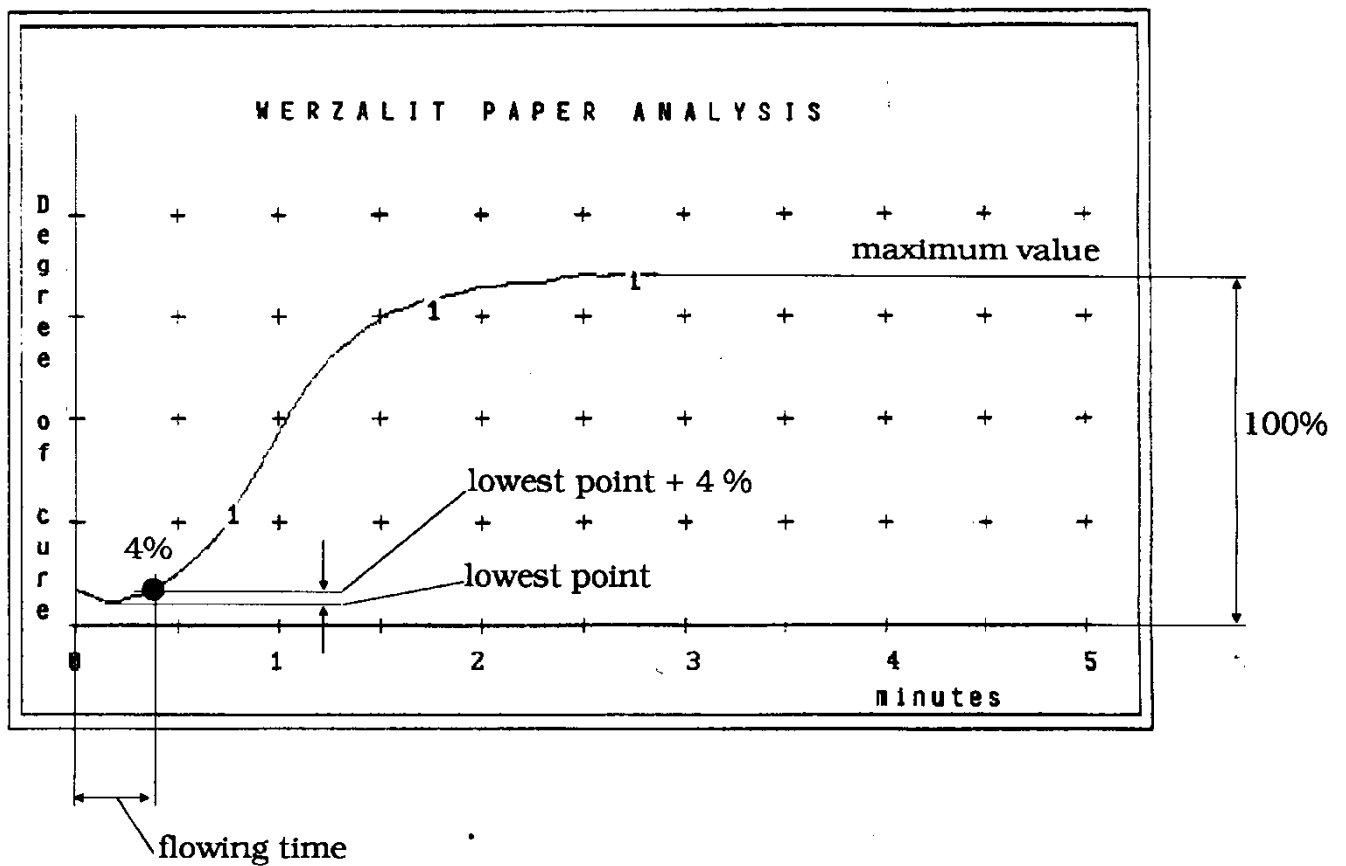



6.4.5 Flexibility [%]

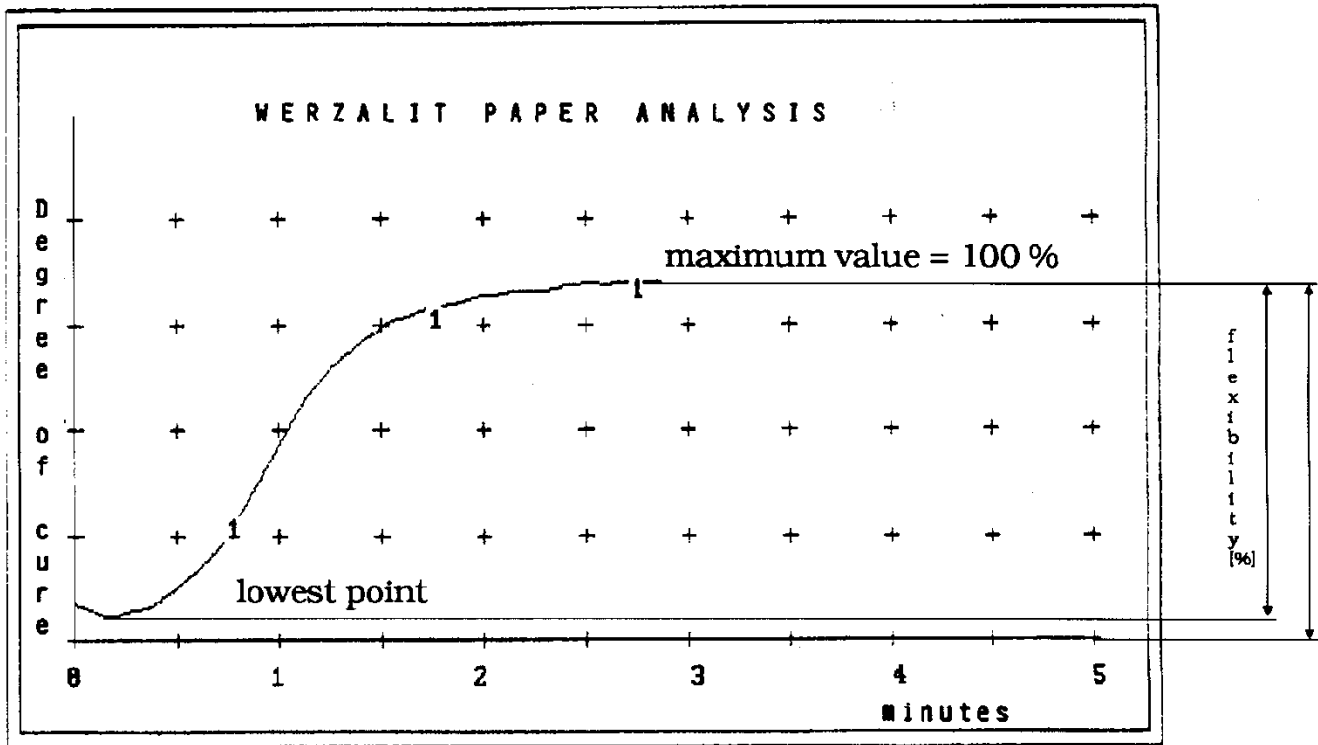

Flexibility is calculated based on the minimum and maximum values.







6.5 Switch off device in case of emergency (Emergency Stop)

Besides the controlled shutting down of the device, it may also be switched off immediately in case of emergency. For this, switch off the main switch.

 CAUTION	
	<ul style="list-style-type: none">▪ If there is a risk of personal injury or another emergency situation, the main switch / EMERGENCY STOP must be switched to OFF immediately.

6.6 Restart after stop

 CAUTION	
	<p>The required measures for restarting the device after a stop are dependent on the cause of the stop.</p> <p>In case of any malfunction, switch the main switch to OFF.</p>

6.7 Switch off device

Prerequisites

Measurement is complete.

Procedure

- 1 Switch off main switch.
- 2 Cover bath opening.



6.8 Test and examine safety equipment

**NOTE!**

The test and safety equipment must be checked regularly, if possible daily or prior to operation.

Defective protective or safety equipment must be replaced immediately.

Device must be switched off and secured until protective or safety equipment is replaced or installed.

Any manipulation or bypassing of protective or safety equipment is prohibited and may result in legal consequences.



7 Cleaning, maintenance



7.1 Maintenance intervals

Maintenance is required no later than every 12 months. Maintenance details may be requested from Mess- & Analysensysteme Golombek GmbH. Mess- & Analysensysteme Golombek GmbH also carries out maintenance jobs, if ordered.

7.2 Maintenance



Maintenance must be carried out in accordance with the device's maintenance instructions. The device operator is responsible for the scope and execution of maintenance work.



7.3 Cleaning

 CAUTION	
	Cleaning agents and cleaning procedures not suited for the device may cause heavy damage to the device.
	<ul style="list-style-type: none">▪ Before you start any cleaning procedure, switch the main switch / EMERGENCY STOP to OFF.▪ Do not clean device with heated steam or solvents.▪ Before you clean the device (for example, with water), for reasons of safety and function, make sure that no liquids will penetrate through openings (cover openings, if necessary). This applies specifically for electric motors and switch cabinets.▪ Do not use metal objects for removing dirt.▪ Do not use high-pressure cleaners for cleaning bearings.▪ Let device cool down before cleaning. Completely remove all added covers after cleaning.





7.4 Checks



 DANGER	
 	Mechanical or electrical hazards through manipulated safety equipment.
	This may result in most severe or fatal injuries.
	Safety equipment must not be removed, bypassed, circumvented or put out of operation. It must be checked for proper function and operability on a daily basis. This applies specifically after retrofitting, overhauling or repair work on the machine or the switch cabinet. Any identified defects must be repaired immediately.

 WARNING	
	<p>The works listed below must be carried out by persons only that fulfill the stated minimum requirements:</p> <ul style="list-style-type: none"> ▪ Mechanics (work on the mechanical parts) ▪ Electrically qualified persons (work on the electric parts) ▪ Operators that have the necessary skills, after being instructed (individual work)

7.5 Special tools

 CAUTION	
	<ul style="list-style-type: none"> ▪ No third-party assemblies must be fitted to the device without prior checks by and consent of Mess- & Analysensysteme Golombek GmbH. ▪ Special tools are not required.

7.6 Preventive maintenance

 CAUTION	
	<ul style="list-style-type: none"> ▪ After carrying out mechanical or electrical work on the device, you must ensure that all and any intended safety equipment is fully functional again.

**CAUTION**

- Any defective or worn parts must be replaced immediately in order to prevent consequential damage or extra downtimes.
- All required maintenance work on additional units must be carried out in accordance with their manufacturers' instructions (for example, drive motors, heating unit).

7.7 Corrective maintenance**CAUTION**

In case of any malfunction, turn main switch to OFF and disconnect all power cords from mains.
Access to the switch cabinet must be restricted to persons with the relevant technical training only.
After carrying out corrective maintenance work on the device, you must ensure that all and any intended safety equipment is fully functional again. Minor mechanical repairs without influence on the device safety may be carried out by the machine operator on his/her own, if such personnel is skilled and qualified to carry out such repairs in line with generally accepted technical standards. Mess- & Analysensysteme Golombek GmbH does not accept any liability for any malfunctions resulting thereof or any consequential damage.

The following must be carried out by specialist personnel from Mess- & Analysensysteme Golombek GmbH only:

- Changes to the device's basic settings.



8 Troubleshooting, error messages

8.1 Safety instructions

- While finding causes for malfunctions or errors, the device may still be energised, therefore you must act with special care.
- For remedying faults or errors, the device **MUST** be shut off and disconnected from mains; it must be protected against accidental switching on.
- Before switching on again, check for correct wiring and connection.
- Inspect safety equipment.



8.2 Indicate and correct faults

Correction of faults and errors **MUST** be carried out by authorised skilled personnel only.

8.3 Error messages and troubleshooting

- Malfunctions or errors are indicated by error messages on the device controller.
- 
 - Malfunctions and errors **MUST** be corrected by authorised personnel only. For all work correcting malfunctions or errors, switch off the device and disconnect from mains, protect against accidental switching on.
 - Restart the device only after correction of malfunction / error and if protective and safety equipment is functional and operable.

9 General information

CAUTION	
	<p>Troubleshooting or reaching into the direct hazard zone of the device is allowed only with the main switch/EMERGENCY STOP switched to OFF.</p>
	<p>If the AUTOMATIC program sequence is interrupted, runs incompletely or faultily, any residues of cleaning agent must be thoroughly removed from the wheel (rinse with fresh water manually). Otherwise, there is the risk of damage to the wheel, especially the rim. Mess- & Analysensysteme Golombek GmbH does not accept any liability for this.</p>



10 Safety equipment

CAUTION



- Safety equipment must not be made ineffective. This applies in any case.
- Any damage to it must be reported immediately.
- Stop operation of the device until damage is repaired and protect against accidental switching on.



11 Service by Mess- & Analysensysteme Golombek GmbH

Customer service

Mess- & Analysensysteme Golombek GmbH

Eichhaldenstr. 73

D-71720 Oberstenfeld

Telephone +49 (0) 7062 5607

Fax +49 (0) 7062 3873

Email: info@folienanalyse.de

12 Supplier's liability

- Notification of any defect must be made to us without delay, but no later than 10 days from receipt of the goods.
- Fitness for a specific purpose is guaranteed only if Mess- & Analysensysteme Golombek GmbH confirms such fitness in writing.
- Mess- & Analysensysteme Golombek GmbH does not guarantee that the deliverable can be used at the location intended by the customer. Including but not limited, the customer must clarify in advance whether the relevant municipality allows dumping waste water into the sewage system if the deliverable is used or if it requires any water treatment. □ Mess- & Analysensysteme Golombek GmbH is not responsible for any damage caused if the deliverable is used despite conflicting conditions on site and is not liable to pay any damages.
- The technical data included in the product description also contain information as regards approved consumables (for example, cleaning agents). If other material is used than described therein or material of different composition, any resulting or caused damage shall not result in any damage claims against □ Mess- & Analysensysteme Golombek GmbH. Any liability in this regard shall be excluded.
- In case of injury to life, body or health resulting from any negligent breach of duty on the part of □ Mess- & Analysensysteme Golombek GmbH or intentional or negligent breach of duty on the part of the legal representatives or employees of Mess- & Analysensysteme Golombek GmbH, Mess- & Analysensysteme Golombek GmbH shall be liable as provided by the law. The same applies for other damage resulting from grossly negligent breach of duty on the part of Mess- & Analysensysteme Golombek GmbH or intentional or grossly negligent breach of duty on the part of the legal representatives or employees of Mess- & Analysensysteme Golombek GmbH. For any other damage resulting from the breach of material obligations, which are the consequence of ordinary negligence or negligent breach of duty of the legal representatives or employees of Mess- & Analysensysteme Golombek GmbH, liability shall be limited to foreseeable, typical damage up to the value of the subject matter of the sales contract. Excluded shall be damage claims for other damage in case of violations of secondary obligations resulting from ordinary negligence. Mess- & Analysensysteme Golombek GmbH shall not be liable for other damage from default resulting from ordinary negligence; this does not affect the customer's statutory rights after expiration of a reasonable grace period.



-
-



Any further claims for damages, reduction of payment or withdrawal from contract shall be excluded; the same applies for claims for compensation of any indirect damage or damage that exceeds the value of the shipment. Above disclaimers or limitations of liability shall not apply if Mess- & Analysensysteme Golombek GmbH has fraudulently concealed any defect or if a specific property or quality of the deliverable is guaranteed by contract. Customer's claims for compensation of useless expenses instead of damages in place of performance shall remain unaffected.

Claims under above paragraph shall be subject to the statute of limitations. All other claims of the customer shall become statute-barred after expiration of 12 months' time.

13 Sub-supplier documentation

For third party devices or functional units installed in this device, the documentation supplied by their respective suppliers applies. Such data sheets, catalogues, operating manuals, tables or descriptions are attached.

- Julabo Circulator

 CAUTION	
	<ul style="list-style-type: none">▪ Safety instructions and warnings of third manufacturer must be observed.



14 Declaration of conformity Film analysis

EC Declaration of Conformity

For the purpose of the EC directives on

- Machinery 2006/42/EC, Annex II 1A
- Low voltage 2006/95/EC

Type of machine

Make: **Device for Film Analysis**

Art. No.

Has been developed, designed and manufactured in accordance with above directives, in the sole responsibility of

Company : **Mess- & Analysensysteme Golombek GmbH**
Eichhaldenstr. 73
71720 Oberstenfeld
Germany

The following harmonised standards have been applied:

- DIN EN 953, Safety of machinery – Guards
- DIN EN ISO 12100-1-2, Safety of machinery
- DIN EN ISO 13849-1, Safety of machinery – safety-related parts of control systems
- DIN EN 60204-1, Electrical equipment of machines
- DIN EN ISO 13857, Safety distances to prevent hazard zones being reached by upper and lower limbs
- DIN EN ISO 13850, Safety of machinery – Emergency Stop - Principles for design
- DIN EN 349 Safety of machinery – Minimum gaps to avoid crushing of parts of the human body

Name and address of person responsible for documentation:

Name:
 Place: Street:
 Telephone:

The operating manual for the device is present.

- as original version (German)
- as translated version (English)

.....
 Place, Date

Signature Information about signatory